

Additional Installation,  
Operation and Maintenance Instructions



# SCUBA

Close-coupled submersible pump unit

# Table of Contents

1	Introduction and Safety .....	4
1.1	Introduction .....	4
1.2	Safety .....	4
1.2.1	Danger levels and safety symbols .....	4
1.2.2	User safety .....	5
1.2.3	Protection of the environment.....	6
1.2.4	Sites exposed to ionizing radiations.....	6
2	Handling and Storage.....	7
2.1	Handling of the packed unit .....	7
2.2	Unit inspection upon delivery.....	7
2.3	Unit handling .....	8
2.4	Storage .....	9
3	Technical Description .....	10
3.1	Designation .....	10
3.2	Data plate .....	10
3.3	Identification code .....	11
3.4	Names of the main components .....	12
3.5	Intended use.....	13
3.6	Improper use .....	13
3.7	Use in water distribution networks for human consumption .....	14
4	Installation .....	15
4.1	Precautions .....	15
4.2	Installation area .....	15
4.2.1	Permitted positions .....	16
4.2.2	Float adjustment.....	16
4.3	Hydraulic connection .....	17
4.3.1	Guidelines for the hydraulic system .....	17
4.4	Electrical connection .....	19
4.4.1	Ground.....	19
4.4.2	Guidelines for electrical connection.....	19
4.4.3	Guidelines for the control electric panel.....	20
4.4.4	Operation with frequency converter .....	20
5	Use and operation .....	21
5.1	Precautions .....	21
5.2	Rotation direction check (three-phase motors) .....	21
5.2.1	Wrong rotation direction .....	21
5.3	Starting and stopping .....	22

---

6	Maintenance .....	23
6.1	Precautions .....	23
6.2	Maintenance every 6 months of operation, or at the end of the season .....	23
6.3	Anode maintenance .....	23
6.4	Long periods of inactivity.....	24
6.5	Spare parts ordering .....	24
7	Troubleshooting.....	25
7.1	Precautions .....	25
7.2	The unit does not start .....	25
7.3	There is little or no flow rate and/or pressure.....	25
7.4	The unit starts up too frequently (automatic start/stop).....	26
7.5	The unit never stops (automatic start/stop) .....	26
7.6	The differential protection device (RCD) is activated .....	26
7.7	The thermal overload protection triggers or the fuses blow .....	26
7.8	The thermal overload protection triggers.....	27
7.9	Excessive anode consumption .....	27
7.10	The unit produces excessive noise and/or vibrations .....	27
7.11	The frequency converter is in error mode or turned off.....	27
8	Technical Information .....	28
8.1	Operating environment .....	28
8.2	Maximum head.....	28
8.3	Maximum operating pressure .....	29
8.4	Maximum number of starts per hour.....	29
8.5	Mechanical characteristics .....	29
8.6	Electrical specifications .....	29
8.7	Sound pressure .....	30
8.8	Materials in contact with the liquid .....	30
9	Disposal.....	31
9.1	Precautions .....	31
10	Declarations.....	32
10.1	EC Declaration of Conformity (Original).....	32
10.2	EU Declaration of Conformity (n. EMCD36).....	32
10.3	EU Declaration of Conformity (n. EMCD08).....	33
11	Warranty .....	34
11.1	Information .....	34

# 1 Introduction and Safety

## 1.1 Introduction

### Purpose of this manual

This manual provides information on how to do the following in the correct manner:

- Installation
- Operation
- Maintenance.



---

### CAUTION:

This manual is an integral part of the unit. Make sure to have read and understood the manual before installing the unit and putting it to use. The manual must always be made available to the user, stored in the proximity of the unit, and well kept.

---

### Supplementary instructions

The instructions and warnings of this manual apply to the standard unit as described in the sale documentation. Special version pumps may be supplied with supplementary instruction manuals. For situations not considered in the manual or in the sales document, contact Xylem or the Authorised Distributor.



## 1.2 Safety

### 1.2.1 Danger levels and safety symbols







Before using the unit, the user must read, understand and comply with the indications of the danger warnings in order to avoid the following risks:

- Injuries and health hazards
- Damage to the product
- Unit malfunction.

### Danger levels

Hazard level	Indication
 <b>DANGER:</b>	It identifies a dangerous situation which, if not avoided, causes serious injury, or even death.
 <b>WARNING:</b>	It identifies a dangerous situation which, if not avoided, may cause serious injury, or even death.
 <b>CAUTION:</b>	It identifies a dangerous situation which, if not avoided, may cause small or medium level injuries.
<b>NOTICE:</b>	It identifies a situation which, if not avoided, may cause damage to property but not to people.

## Complementary symbols

Symbol	Description
	Electrical hazard
	Hot surface hazard
	Danger, system pressurized
	Do not use flammable liquids
	Do not use corrosive liquids
	Protect against freezing
	Read the instruction manual

## 1.2.2 User safety

Strictly comply with current health and safety regulations.

**WARNING:**

This unit must be used only by qualified users. Qualified users are people able to recognise the risks and avoid hazards during installation, use and maintenance of the unit.

## Inexperienced users

**WARNING:**

- For EU countries: this product may be used by children aged 8 years and above and persons with reduced physical, sensory or mental capabilities, or who lack experience and knowledge, provided that they are being supervised and have been instructed on how to use it safely, and understand the hazards involved. Children must not play with the product. Cleaning and maintenance must not be carried out by children without supervision.
- For countries outside the EU: this product is not intended for use by persons (including children) with reduced physical, sensory or mental capabilities, or who lack experience and knowledge, unless they are being supervised and have been instructed on how to use it by a person responsible for their safety. Children should be supervised to ensure that they do not play with the product.

### 1.2.3 Protection of the environment

#### Disposal of packaging and product

Comply with the current regulations on sorted waste disposal.

#### Leaking of fluid

The unit contains a small quantity of lubricant oil: always put in place the necessary measures to ensure that any spilled lubricant does not disperse in the environment.



---

**WARNING:**

It is prohibited to dispose of lubricating fluids and other hazardous substances in the environment.

---

### 1.2.4 Sites exposed to ionizing radiations



---

**WARNING: Ionizing radiation hazard**

If the unit has been exposed to ionizing radiations, implement the necessary safety measures for the protection of people. If the unit needs to be despatched, inform the carrier and the recipient accordingly, so that appropriate safety measures can be put in place.

---

# 2 Handling and Storage

## 2.1 Handling of the packed unit



**WARNING:** Crushing hazard (limbs)

The unit and its components may be heavy: risk of crushing.



**WARNING:**

Always wear personal protective equipment.



**WARNING:**

Check the gross weight marked on the packaging.



**WARNING:**

Handle the unit in compliance with the current regulations on "manual load handling", to avoid undesirable ergonomic conditions causing risks of back-spine injury.



**WARNING:**

Take appropriate measures during transport, installation and storage to prevent contamination from external substances.

The Manufacturer delivers the unit and its components in a cardboard box.

## 2.2 Unit inspection upon delivery

### Inspect the package

1. Check that quantity, descriptions and product codes match the order.
2. Check the packaging for any damage or missing components.
3. In case of immediately detectable damage or missing parts:
  - accept the goods with reserve, indicating any findings on the transport document, or
  - reject the goods, indicating the reason on the transport document.

In both cases, promptly contact Xylem or the Authorised Distributor from whom the product was purchased.

### Unpacking and inspection of the unit



**CAUTION:** Cut and abrasion hazard

Always wear personal protective equipment.

1. Remove packing materials from the product.
2. Check the unit for integrity and to make sure that there are no missing components.
3. In case of damage or missing components, promptly contact Xylem or the Authorised Distributor.

## 2.3 Unit handling

Lift the unit by attaching a rope to the lifting ring.



**DANGER: Electrical hazard**

Holding the unit by the power supply cord or the float is strictly forbidden.

---

---



**WARNING:**

Use cranes, ropes, lifting straps, hooks and clasps that comply with current regulations and that are suitable for the specific use.

---

---

**NOTICE:**

Make sure that the harnessing does not hit and/or damage the unit.

---

---



**WARNING:**

Lift and handle the unit slowly to avoid stability issues.

---

---



**WARNING:**

During handling, make sure to avoid injury to people and animals, and/or damage to property.

---

---



## 2.4 Storage

### Storage of the packed unit

The unit must be stored:

- In a covered and dry place
- Away from heat sources
- Protected from dirt
- Protected from vibrations
- At an ambient temperature between -5°C and +60°C (23°F and 140°F), and relative humidity between 5% and 95%.

---

**NOTICE:**

Do not place heavy loads on top of the unit.

---

**NOTICE:**

Protect the unit from collisions.

---

### Long-term storage of the unit

1. Keep the unit in the vertical position and empty it completely through the filter.



2. Follow the same instructions for the storage of the packed unit.

For further information about preparation for long-term storage, please contact Xylem or the Authorised Distributor.

# 3 Technical Description

## 3.1 Designation

Multistage close-coupled submersible pump unit with threaded port.

## 3.2 Data plate

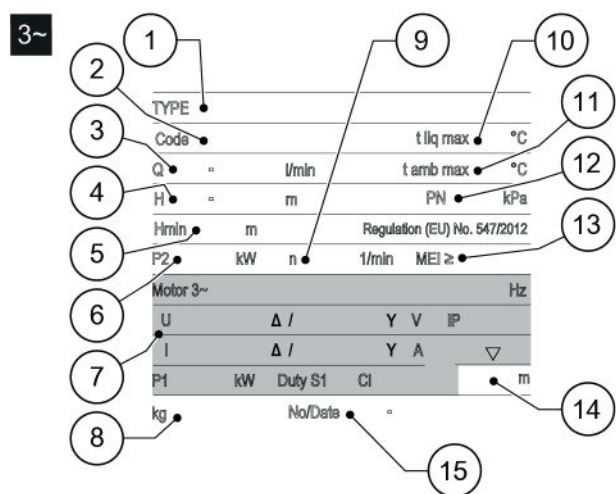
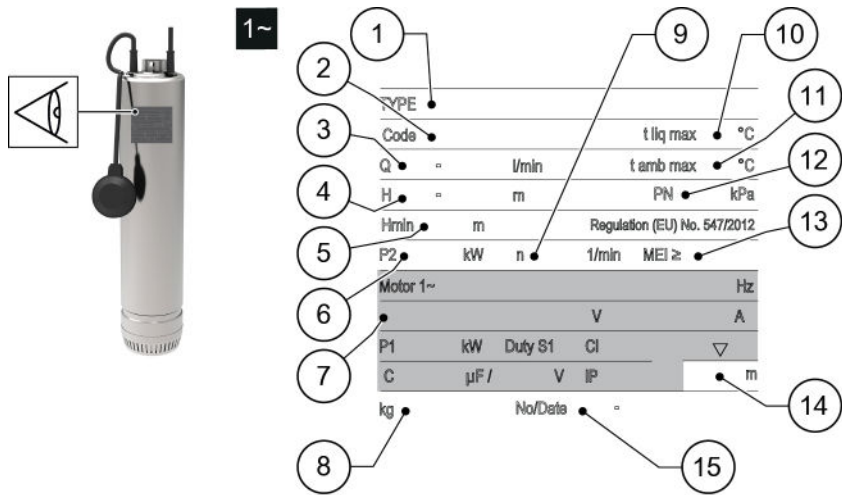

Scuba\_M0005\_C\_sc

Position number	Description	Position number	Description
1	Pump unit type	9	Speed
2	Pump unit code	10	Maximum liquid temperature
3	Flow	11	Maximum ambient temperature
4	Head	12	Maximum operating pressure
5	Minimum head	13	Minimum efficiency index MEI
6	Rated output	14	Maximum immersion depth
7	Motor characteristics	15	Serial number + manufacturing date
8	Weight	-	-

### 3.3 Identification code

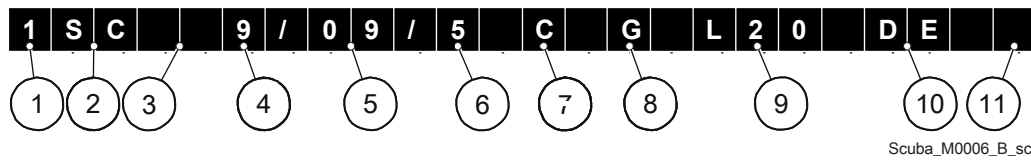

Position number	Description	Notes
1	Rated flow rate, m <sup>3</sup> /h	
2	Series	SC = Scuba
3	Version	Empty = standard D = DRY DS = DRY submersible
4	Number of impeller	
5	Rated motor power, kW x 10	
6	Frequency Hz	5 = 50 Hz 6 = 60 Hz
7	Power supply and capacitor	C = single-phase with internal capacitor Q = single-phase with external capacitor T = three-phase
8	Float	Empty = without float G = with float
9	Cable length, m	
10	Plug type	Empty = not included DE = German, CEE 7-VII, DIN49441-2-AR2 UK = British, BS 1363-I AU = Australian, AS/NZS 3112
11	Certification for use with drinking water	Empty = none W = WRAS

#### Marks of safety approval

For products with a mark of electrical-related safety approval such as IMQ, TUV, IRAM, etc., the approval refers exclusively to the pump unit.

### 3.4 Names of the main components

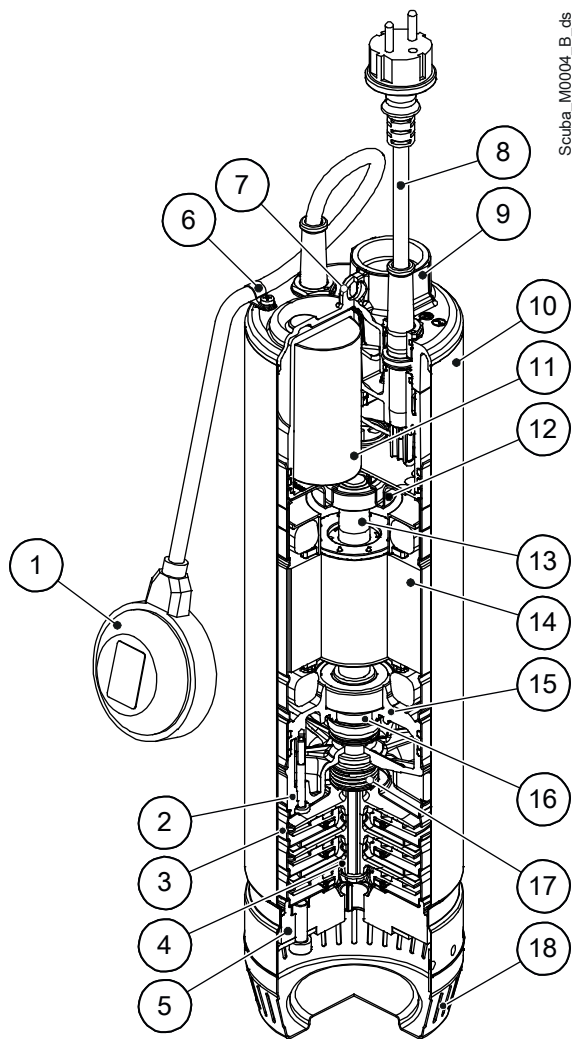

Position number	Description	Position number	Description
1	Float (optional)	10	Sleeve
2	Lower bracket	11	Capacitor
3	Diffuser	12	Upper bearing support
4	Impeller	13	Shaft and bearings
5	Bush bearing bracket	14	Stator casing
6	Floater adjustment clip	15	Lower bearing support
7	Lifting ring	16	Internal mechanical seal (oil chamber)
8	Power supply cord	17	External mechanical seal
9	Discharge port	18	Filter

### 3.5 Intended use

- Water supply from first collection tanks, wells for domestic use, basins and water streams
- Irrigation
- Pressure boosting systems
- Rain water collection tanks
- Vehicle washing systems
- Craft pressure boosting systems
- Air purification and humidification
- Water filtering and recycling systems.

Observe the operating limits in **Technical Information** on page 28.

#### Pumped liquids

- Clean
- Free of solid particles or fibres
- Chemically and mechanically non aggressive
- Non-flammable.

### 3.6 Improper use



---

#### WARNING:

The unit was designed and built for the use described in the Intended Use section. Any other uses are prohibited, as they could compromise the safety of the user and the efficiency of the unit itself.

---



---

#### DANGER:

It is prohibited to use this unit to pump flammable and/or explosive liquids.

---



---

#### DANGER: Potentially explosive atmosphere hazard

It is prohibited to start the unit in environments with potentially explosive atmospheres or with combustible dusts.

---

#### Examples of improper use

- Pumping liquids not compatible with the construction materials of the unit
- Pumping hazardous, toxic, explosive, flammable or corrosive liquids
- Pumping drinking liquids other than water, for example wine or milk
- Pumping liquids containing abrasive, solid, or fibrous substances
- Using the unit for flow rates exceeding the flow rate indicated in the data plate.

#### Examples of improper installation

- Explosive and corrosive atmospheres.

### 3.7 Use in water distribution networks for human consumption

If the unit is intended for water supply to people and/or animals:

---



**WARNING:**

It is prohibited to pump drinking water after use with other fluids.

---



**WARNING:**

Take appropriate measures during transport, installation and storage to prevent contamination from external substances.

---



**WARNING:**

Remove the unit from its packaging just before installation to prevent contamination from external substances.

---



**WARNING:**

After installation, run the unit for a few minutes with several users open in order to wash the inside of the system.

---

# 4 Installation

## 4.1 Precautions

Before starting, make sure that the safety instructions shown in **Introduction and Safety** on page 4 have been fully read and understood.



**DANGER:**

All the hydraulic and electrical connections must be completed by a technician possessing the technical-professional requirements outlined in the current regulations.



**DANGER: Potentially explosive atmosphere hazard**

It is prohibited to start the unit in environments with potentially explosive atmospheres or with combustible dusts.



**WARNING:**

Always wear personal protective equipment.



**WARNING:**

Always use suitable working tools.



**WARNING:**

When selecting the place of installation and connecting the unit to the hydraulic and electric power supplies, strictly comply with current regulations.

**NOTICE:**

In case of outdoor installation, ensure protection from frost.

When connecting the unit to a public or private aqueduct, or to a well for the supply of water for human and/or animal consumption, see **Use in water distribution networks for human consumption** on page 14.

## 4.2 Installation area

1. Follow the provisions in **Operating environment** on page 28.
2. Remove any solid sediments found.
3. Check that the well or the tank are of appropriate size for housing the unit, with an even perimeter without obstacles.
4. Check that the sizes of the well/tank do not hinder the free movement of the float, if present.

### 4.2.1 Permitted positions

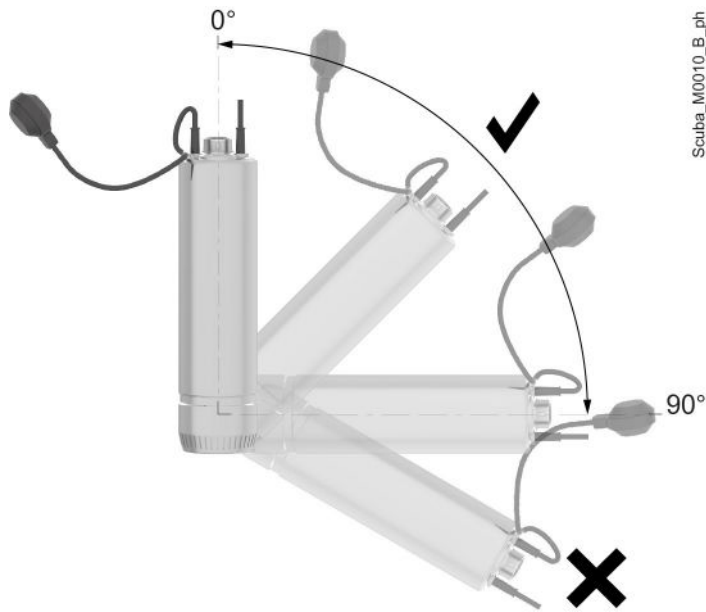

### 4.2.2 Float adjustment

If present, the float switch controls the automatic start and stop of the unit. To change its action:

1. Loosen the floater adjustment clip screw.

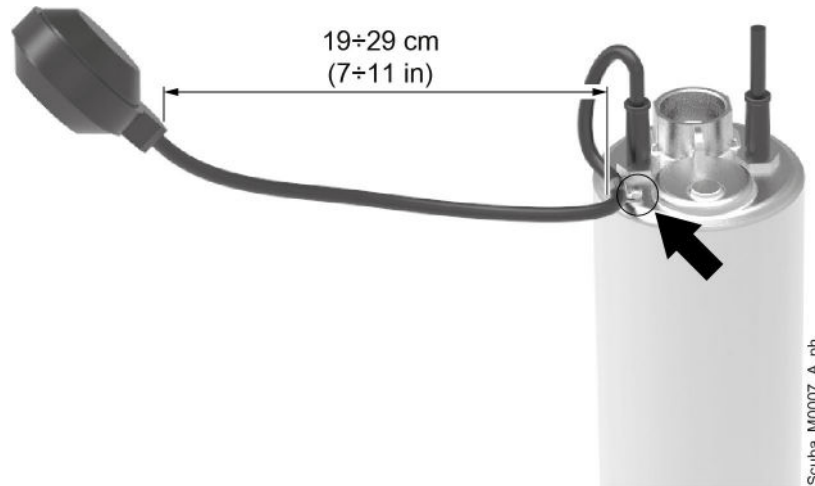

2. Adjust the length of the float cable:
  - short: decrease the distance between minimum and maximum level, more frequent starts and stops.
  - long: increase the distance between minimum and maximum level, less frequent starts and stops.
3. Tighten the screw.  
Tightening torque: 1.5 Nm (13 lbf-in).

---

**NOTICE:**

The cable length must not be less than 19 cm (7 in).

---



## 4.3 Hydraulic connection



### DANGER:

All the hydraulic and electrical connections must be completed by a technician possessing the technical-professional requirements outlined in the current regulations.



### DANGER: Electrical hazard

Holding the unit by the power supply cord or the float is strictly forbidden.



### WARNING:

Piping must be sized to ensure safety at the maximum operating pressure.



### WARNING:

Install appropriate seals between the unit couplings and the pipings.

### 4.3.1 Guidelines for the hydraulic system

1. Connect the piping to the unit discharge port:
  - a) In case of metal piping, this should be screwed directly to the port;
  - b) In case of plastic piping, use an adapter.

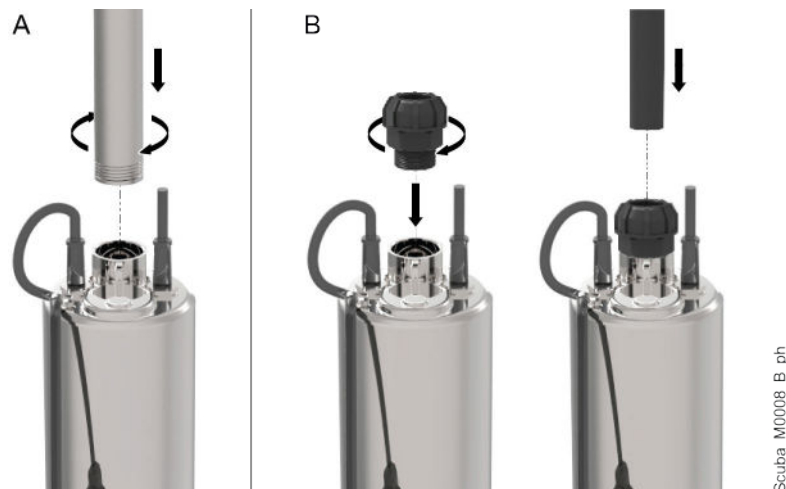

2. Install a check valve on the piping, at least 2 m (7 ft) from the unit, and then one every 10 m (33 ft).
3. Make a 3 mm (1/8") relief hole 10 cm (3.9 in) from the discharge port.
4. Secure the power supply cord to the piping with nylon ties at distances of 3 m (10 ft) from each other, keeping it loose from one tie and the next, to avoid it being pulled in case of piping expansion.
5. Secure a rope made of non-perishable material to the lifting ring.
6. Lower the unit in the well/tank holding it with the rope.
7. Position the unit:
  - At the centre of the well/tank
  - Submerged in the liquid at a depth of at least 15 cm (6 in)
  - At a maximum depth of 17 m (56 ft) from the maximum level of the liquid
  - At a minimum distance of 50 cm (20 in) from the bottom of the well/tank
  - With at least 3 m (10 ft) of power supply cord out of the liquid
  - With the float, if installed, at least 5 cm (2 in) from the wall of the well/tank.

The figure shows a typical installation.

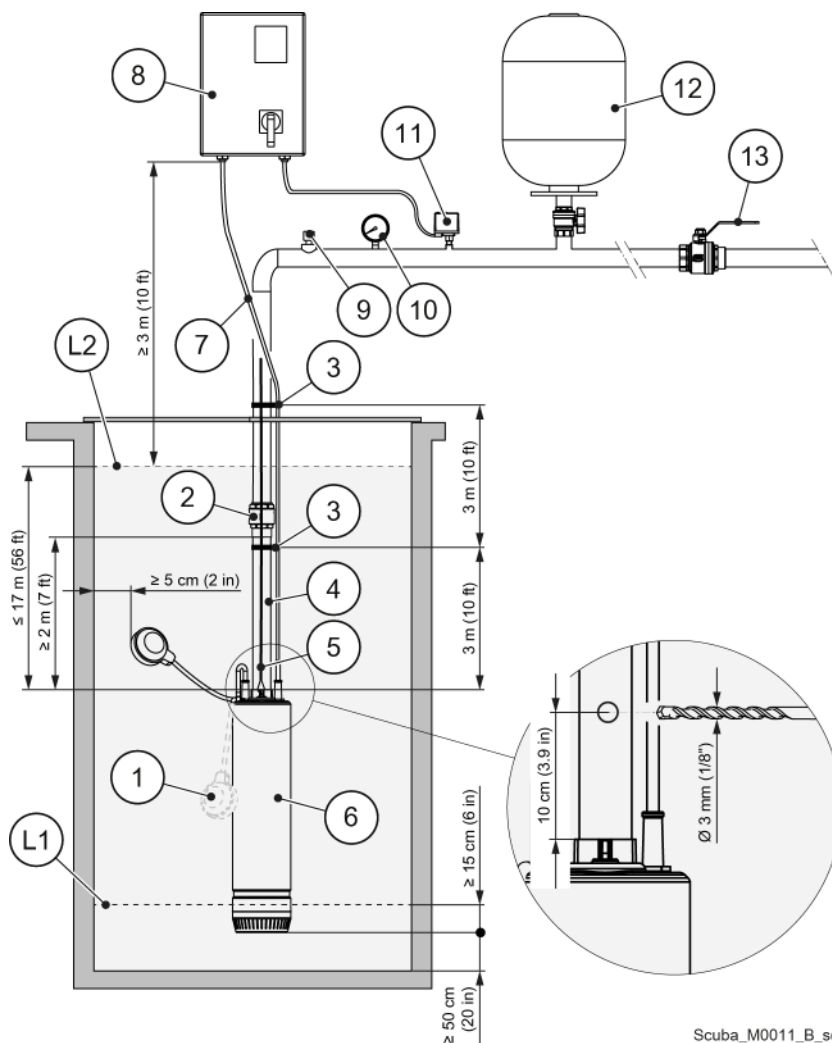

Scuba\_M0011\_B\_sc

Position number	Description	Position number	Description
L1	Minimum level	7	Electric power supply cord
L2	Maximum level	8	Control panel
1	Float	9	Bleed valve
2	Check valve	10	Pressure gauge
3	Nylon tie	11	Start and stop device
4	Piping	12	Diaphragm tank
5	Lifting rope	13	Gate valve
6	Unit	-	-

**NOTICE:**

In the operating position, the unit, the piping, the electric power supply cord and the lifting rope must never be in contact with the walls of the well/tank.

## 4.4 Electrical connection



**DANGER:**

All the hydraulic and electrical connections must be completed by a technician possessing the technical-professional requirements outlined in the current regulations.



**DANGER: Electrical hazard**

Before starting work, check that the unit is unplugged and that the pump unit, the control panel and the auxiliary control circuit cannot restart, even unintentionally.

### 4.4.1 Ground



**DANGER: Electrical hazard**

Always connect the external protection conductor (ground) to the ground terminal before attempting to make any other electrical connections.



**DANGER: Electrical hazard**

Connect the pump unit and any electric accessories to a socket with protection conductor (ground).



**DANGER: Electrical hazard**

Check that the external protection conductor (ground) is longer than the phase conductors; In case of accidental disconnection of the unit from the phase conductors, the protection conductor must be the last one to detach itself from the terminal.



**DANGER: Electrical hazard**

Install suitable systems for protection against indirect contact, in order to prevent lethal electric shocks.

### 4.4.2 Guidelines for electrical connection

1. Check that:
  - The mains voltage and frequency match the specifications on the data plate
  - The power supply cord is protected from high temperatures, vibrations, collisions and abrasions.
2. Check that the power supply line is provided with:
  - A short circuit protection device of appropriate size
  - A mains disconnection device with contact opening distance ensuring complete disconnection for overvoltage III category conditions
  - For use in swimming pools, garden ponds or similar, and only when inside there are no people or animals, a residual current earth leakage switch (IΔN) ≤ 30 mA
  - If it is not possible to visually check the level of the liquid, install a system for protection against dry run connected to a pressure switch (or float, probes, or other suitable devices)
  - In case of permanent installation, install an RCCB earth leakage switch with tripping current ≤ 30 mA.

#### Overtemperature protection - single-phase motor unit



**DANGER: Electrical hazard**

Connect the plug to a socket with protection conductor (earth).

The unit is equipped with built-in capacitor and motor protector, and stops automatically in case of overtemperature.  
After 2-4 minutes the motor protector gives the restart consent.

**Overtemperature protection - three-phase motor unit**

Install an appropriate motor protector in the control panel, with D curve in accordance with the current shown in the data plate.

**Motor without automatic reset thermal overload protection**

1. If the motor is used with full load, then set the value to the nominal current value on the data plate.
2. If the motor is used with partial load, then set the value of the operating current measured with a current pincer.

**4.4.3 Guidelines for the electrical control panel**

**NOTICE:**

The electric panel must match the ratings on the data plate. Improper combinations could damage the motor.

- Install appropriate devices for protecting the motor from overloads and short circuits:

Motor	Safety features
Single-phase	<ul style="list-style-type: none"> <li>• Automatic reset thermal-ampere protection, built-in (motor protector)</li> <li>• From short circuit, by the installer: aM fuses (motor start-up), or thermal magnetic switch with C curve and <math>I_{cn} \geq 4.5 \text{ kA}</math>, or other similar device.</li> </ul>
Three-phase	<ul style="list-style-type: none"> <li>• Thermal, by the installer: trip class 10 A overload thermal relay + aM fuses (motor start-up), or start class 10 A motor protection thermal magnetic switch</li> <li>• From short circuit, by the installer: aM fuses (motor start-up), or thermal magnetic switch with C curve and <math>I_{cn} \geq 4.5 \text{ kA}</math>, or other similar device.</li> </ul>

- If required, install phase failure sensitive thermal relays.

**4.4.4 Operation with frequency converter**

Single-phase and three-phase motors can be connected to a frequency converter for speed control.

- The converter exposes the insulation of the motor to a greater load, determined by the length of the connecting cable: observe the requirements of the Manufacturer of the frequency converter
- The minimum frequency must not fall below 25 Hz
- The head of the unit must never be below 2 m (6.5 ft)
- For applications requiring silent operation, install an outlet filter between the motor and the converter; a sinusoidal filter can reduce the noise even further
- The conditions of installation must guarantee protection against voltage peaks between the terminals and/or  $dV/dt$  in the table:

Motor size	Voltage peak, V	$dV/dt$ , V/ $\mu\text{s}$
up to 90R (500 V)	< 650	< 2200
from 90R to 180R	< 1400	< 4600
over 180R	< 1600	< 5200

Otherwise, use a motor with reinforced insulation<sup>1</sup> and a sinusoidal filter.

<sup>1</sup> Available on request

# 5 Use and operation

## 5.1 Precautions



**DANGER: Electrical hazard**

Do not use the unit in swimming pools or similar places when people are inside.



**WARNING:**

Make sure that the drained liquid cannot cause damage or injuries.



**WARNING: Electrical hazard**

Check that the unit is properly connected to the mains power supply.



**WARNING: Injuries hazard**

The unit, equipped with a single-phase motor with automatic reset thermal overload protection, could restart inadvertently after it has cooled down: risk of physical injury.



**WARNING:**

It is prohibited to put combustible materials near the unit.

**NOTICE:**

The unit must be submerged in the liquid at a depth of at least 15 cm (6 in) before startup.

**NOTICE:**

Dry run of the unit is forbidden.

**NOTICE:**

It is prohibited to operate the unit with the on-off valve closed.

**NOTICE:**

Make sure that there is no residual air inside the unit after being submerged in the liquid.

## 5.2 Rotation direction check (three-phase motors)

1. Submerge the unit in the liquid at a depth of at least 15 cm (6 in).
2. Start the unit.
3. Check the discharge pressure gauge:
  - If pressure is detected, the motor rotation direction is correct
  - If no pressure or low pressure is detected, the motor rotation direction is wrong.
4. Stop the unit.

### 5.2.1 Wrong rotation direction

1. Disconnect the power supply.
2. Invert two of the three wires of the power supply cord.

## 5.3 Starting and stopping

### Units with float

1. Connect the plug to the mains and/or turn on the switch: depending on the position of the float, the unit stays idle or starts to operate.
2. With the unit in operation, check that the liquid is actually being pumped and that there is no:
  - Leaking of fluid from the piping
  - Abnormal noise or vibration
  - Vortex nearby the suction port.
3. When the float reaches the low position (minimum liquid level), the pump automatically stops.

### Units without float

1. Connect the plug to the mains and/or turn on the switch: the unit starts.
2. With the unit in operation, check that the liquid is actually being pumped and that there is no:
  - Leaking of fluid from the piping
  - Abnormal noise or vibration
  - Vortex nearby the suction port.
3. Once the unit has taken up liquid to the minimum level, disconnect the plug from the mains and/or turn off the switch to switch it off.

# 6 Maintenance

## 6.1 Precautions

Before starting, make sure that the instructions shown in **Introduction and Safety** on page 4 have been fully read and understood.



**WARNING:**

Maintenance must be done by a technician possessing the technical-professional requirements outlined in the current regulations.



**WARNING:**

Always wear personal protective equipment.



**WARNING:**

Always use suitable working tools.



**WARNING:**

In the case of liquids that are excessively hot or cold, pay attention to the risk of injury.



**DANGER: Electrical hazard**

Before starting work, check that the unit is unplugged and that the pump unit, the control panel and the auxiliary control circuit cannot restart, even unintentionally.



**DANGER: Electrical hazard**

If the unit is connected to the frequency converter, disconnect the mains power supply and wait at least 10 minutes for the residual current to dissipate.

## 6.2 Maintenance every 6 months of operation, or at the end of the season

When the first of the two limits is reached:

1. Check the integrity of the power supply cord; if the cable is damaged contact Xylem or the Authorised Distributor for its replacement.
2. Check the integrity of the float cable, if present; if the cable is damaged contact Xylem or the Authorised Distributor for its replacement.
3. Carefully clean the unit and the filter.

## 6.3 Anode maintenance

1. After the first installation of the unit, estimate the anode wear rate, if present, by inspecting it once a month for 6 months.
2. Depending on the wear rate, afterwards the anode may be inspected every 3 or 6 months.
3. The anode should be replaced when its mass falls below 150 g (5.3 oz); record all replacements in the maintenance log.

**NOTICE:**

In case of excessive anode wear, see **Excessive anode consumption** on page 27.

## 6.4 Long periods of inactivity

1. Units used for pumping salt water must be rinsed with fresh water afterwards.
2. Empty the unit and the piping.
3. Put the unit out of service.
4. Protect the unit against freezing.

Before starting the unit:

1. Remove the filter and check that the shaft is rotating freely, without mechanical impediments.
2. Inspect the anode and replace as necessary; see **Anode maintenance**.

## 6.5 Spare parts ordering

Identify the spare parts with the product codes directly on the site [www.lowara.com/spark](http://www.lowara.com/spark).  
Contact Xylem or the Authorised Distributor for technical information.



# 7 Troubleshooting

## 7.1 Precautions



**WARNING:**

Maintenance must be done by a technician possessing the technical-professional requirements outlined in the current regulations.



**WARNING:**

Observe the safety requirements in the chapters on Use and Operation and Maintenance.



**WARNING:**

If a fault cannot be corrected or is not mentioned, contact Xylem or the Authorised Distributor.

## 7.2 The unit does not start

Cause	Remedy
Power supply cut off	Restore the power supply
Float in the low position	<ul style="list-style-type: none"> <li>• Check the liquid level in the well/tank and/or</li> <li>• Adjust the float and/or</li> <li>• Check that the float can move without impediments.</li> </ul>
The thermal overload protection has triggered	See paragraph 7.7
Power supply cord is damaged	Contact Xylem or the Authorised Distributor for the replacement
Capacitor faulty (system with control panel)	Replace the capacitor
Control panel faulty	Check and repair or replace the control panel
Starter set incorrectly, or faulty	Adjust or replace the starter

## 7.3 There is little or no flow rate and/or pressure

Cause	Remedy
Motor turns in the wrong direction	Check the direction of rotation and change it if necessary
Well liquid level too low	<ul style="list-style-type: none"> <li>• Increase the installation depth, and/or</li> <li>• Reduce the unit performance levels, and/or</li> <li>• Replace the unit with another with lower performance levels.</li> </ul>
Check valve locked in closed or partially closed position	Replace the check valve
Suction filter clogged	Clean the filter
Discharge pipe throttled	Remove the throttling
Piping and/or unit clogged	Remove the clogging
Undervoltage	Check the electric power supply
Liquid leaking from the unit due to corrosion or faulty seals	<ul style="list-style-type: none"> <li>• Check the installation requirements and the limits of use, and/or</li> <li>• Install the sacrificial anode kit and/or</li> <li>• Send the unit to an authorised workshop for testing.</li> </ul>
Presence of air in the unit	<ul style="list-style-type: none"> <li>• Bleed the unit and/or</li> <li>• Make a relief hole, see Guidelines for the hydraulic system.</li> </ul>

## 7.4 The unit starts up too frequently (automatic start/stop)

Cause	Remedy
Float in the low position	<ul style="list-style-type: none"> <li>• Check the liquid level in the well/tank and/or</li> <li>• Adjust the float and/or</li> <li>• Check that the float can move without impediments.</li> </ul>
Check valve blocked	Replace the check valve
Starter set incorrectly, or faulty	Adjust or replace the starter
Expansion vessel <ul style="list-style-type: none"> <li>• no pre-charge, or</li> <li>• undersized, or</li> <li>• not installed</li> </ul>	<ul style="list-style-type: none"> <li>• Pre-charge the expansion vessel, or</li> <li>• replace the expansion vessel with another suitable one, or</li> <li>• install an expansion vessel.</li> </ul>
Oversized unit	Contact Xylem or the Authorised Distributor

## 7.5 The unit never stops (automatic start/stop)

Cause	Remedy
Float in the low position	<ul style="list-style-type: none"> <li>• Check the liquid level in the well/tank and/or</li> <li>• Adjust the float and/or</li> <li>• Check that the float can move without impediments.</li> </ul>
The required flow rate is greater than the one expected	Reduce the required flow rate
Discharge pipe leaking	Eliminate the leaks
Motor turns in the wrong direction	Check the direction of rotation and change it if necessary
Pipes, on-off valves or filter clogged with impurities	Remove the impurities
Starter set incorrectly, or faulty	Adjust or replace the starter
The unit runs but there is little or no flow rate	See paragraph 7.7

## 7.6 The differential protection device (RCD) is activated

Cause	Remedy
Unsuitable type of differential	Check the type of differential
Float damaged	Contact Xylem or the Authorised Distributor for the replacement

## 7.7 The thermal overload protection triggers or the fuses blow

The motor thermal overload protection triggers or the fuses blow when the unit starts.

Cause	Remedy
Liquid temperature too high	Bring the liquid temperature back within the permitted limit
It is calibrated at a value too low in relation to the rated current of the motor	<ul style="list-style-type: none"> <li>• Repeat the thermal overload protection calibration, and/or</li> <li>• Install correctly sized fuses.</li> </ul>
Missing power supply phase	Check the power supply and restore the phase
Thermal overload protection connections loose and/or faulty (system with control panel)	Tighten or replace the clamps and terminals
Unit mechanically seized	Check and repair the unit
Power supply cord is damaged	Contact Xylem or the Authorised Distributor for the replacement
Unit faulty	Send the unit to an authorised workshop for testing

## 7.8 The thermal overload protection triggers

The motor thermal overload protection triggers occasionally, or after the unit has been running for a few minutes.

Cause	Remedy
It is calibrated at a value too low in relation to the rated current of the motor	Recalibrate
Liquid temperature too high	Bring the liquid temperature back within the permitted limit
Input voltage outside the rated limits	Make sure the voltage values are correct
Unbalanced input voltage	Make sure the voltage of the three phases is balanced
Wrong duty point, flow rate below or above the permitted limits	Bring the flow rate back within the permitted limits
Presence of solid or fibrous substances in the liquid (unit overload)	Remove the substances
Frequency converter wrongly calibrated (if present)	See the frequency converter manual

## 7.9 Excessive anode consumption

Cause	Remedy
Electric contact with large size metal parts	Remove the electric contact
Defective grounding	Check and reset the grounding
Eddy current	Remove all eddy current
Liquid too aggressive	<ul style="list-style-type: none"> <li>• Check the compatibility of the unit with the liquid</li> <li>• Check the liquid temperature.</li> </ul>

## 7.10 The unit produces excessive noise and/or vibrations

Cause	Remedy
Resonance	Check the installation
Frequency converter wrongly calibrated (if present)	See the frequency converter manual
Foreign bodies in the unit	Remove the foreign bodies
The unit does not turn freely due to a mechanical fault	Send the unit to an authorised workshop for testing
Wrong duty point, flow rate below or above the permitted limits	Bring the flow rate back within the permitted limits

## 7.11 The frequency converter is in error mode or turned off

The frequency converter (if present) is in error mode or turned off.

Cause	Remedy
See the frequency converter manual	See the frequency converter manual

# 8 Technical Information

## 8.1 Operating environment

Non-aggressive, non-explosive atmosphere, and not subjected to frost.

Temperature of pumped liquid

0 to 40°C (32 to 104°F).

**NOTICE:**

If the temperature exceeds the stated limits, contact Xylem or the Authorised Distributor.

Suspended impurities

Model	Maximum diameter, mm (in)
1SC	≤ 1.0 (0.04)
3SC, 5SC, 8SC	≤ 2.0 (0.08)

Chloride concentration

≤ 200 ppm at 20°C (68°F).

**NOTICE:**

If the concentration is higher, install the sacrificial anode kit.

Sand quantity

≤ 25 g/m<sup>3</sup>.

## 8.2 Maximum head

50 Hz

Model	Head, m (ft)	Model	Head, m (ft)	Model	Head, m (ft)
1SC9/09/5C	75 (245)	3SC8/15/5T	90 (294)	5SC5/09/5T	59 (193)
1SC7/07/5C	60 (197)	3SC7/09/5T	79 (258)	5SC4/07/5T	48 (156)
1SC6/05/5C	101 (331)	3SC5/07/5T	58 (190)	5SC3/05/5T	36 (117)
1SC9/09/5T	78 (257)	3SC4/05/5T	47 (153)	8SC6/15/5C	65 (214)
1SC7/07/5T	61 (201)	5SC8/15/5C	93 (304)	8SC3/09/5C	32 (104)
1SC6/05/5T	102 (335)	5SC6/11/5C	70 (228)	8SC2/05/5C	21 (69)
3SC9/15/5C	91 (298)	5SC5/09/5C	59 (195)	8SC6/22/5T	66 (215)
3SC8/11/5C	78 (255)	5SC4/07/5C	47 (156)	8SC5/15/5T	55 (179)
3SC7/09/5C	57 (186)	5SC3/05/5C	35 (116)	8SC4/11/5T	44 (144)
3SC5/07/5C	45 (149)	5SC8/22/5T	94 (309)	8SC3/09/5T	33 (108)
3SC4/05/5C	101 (331)	5SC7/15/5T	83 (271)	8SC2/05/5T	22 (72)
3SC9/22/5T	75 (245)	5SC6/11/5T	71 (232)	-	-

60 Hz

Model	Head, m (ft)	Model	Head, m (ft)	Model	Head, m (ft)
1SC4/05/6C	58 (191)	5SC4/15/6C	69 (226)	3SC6/15/6T	100 (328)
1SC5/07/6C	73 (238)	8SC2/11/6C	32 (103)	5SC2/07/6T	35 (115)
1SC6/11/6C	86 (283)	8SC3/15/6C	47 (155)	5SC3/11/6T	52 (172)
3SC2/05/6C	33 (107)	1SC3/05/6T	45 (147)	5SC4/15/6T	68 (223)
3SC3/07/6C	49 (161)	1SC4/07/6T	60 (196)	5SC6/22/6T	102 (335)
3SC4/09/6C	65 (214)	1SC5/09/6T	75 (244)	8SC2/11/6T	32 (104)
3SC5/11/6C	82 (268)	1SC6/11/6T	89 (293)	8SC3/15/6T	48 (156)
3SC6/15/6C	98 (321)	3SC2/05/6T	34 (110)	8SC4/22/6T	63 (208)
5SC2/07/6C	34 (112)	3SC3/07/6T	50 (165)	-	-
5SC3/11/6C	51 (167)	3SC4/09/6T	67 (219)	-	-

### 8.3 Maximum operating pressure

1MPa (145 psi).

Note:

$P_{1max} + P_{max} \leq P_N$ .

Data	Description
P1max	Maximum input pressure
Pmax	Maximum pressure generated by the unit
PN	Maximum operating pressure

### 8.4 Maximum number of starts per hour

Motor power, kW	Starts / h
0.5 - 0.9	25
1.1 - 2.2	20

### 8.5 Mechanical characteristics

Electric power supply cord length

20 m (66 ft).

Maximum immersion depth

17 m (56 ft)

Protection class

IPX8.

### 8.6 Electrical specifications

Speed

Frequency Hz	Speed, min <sup>-1</sup>
50	2900
60	3500

Permitted tolerances for the supply voltage

Frequency Hz	Phase ~	No. of conductors + earth	UN, V ± %
50	1	2 + 1	220÷240 ± 6
	3	3 + 1	230/400 ± 10
60	1	2 + 1	220÷230 ± 6
	3	3 + 1	220/380 ± 5

## 8.7 Sound pressure

Unit position	LpA sound pressure level measured in free field at a distance of one metre, dB ± 2
Submerged	Non-applicable
Partially submerged	< 70

## 8.8 Materials in contact with the liquid

Component	Material
Sleeve, diffuser, casing, filter, plate	AISI 304 stainless steel
Bush support, impeller, lower head, upper head	Technopolymer

# 9 Disposal

## 9.1 Precautions



---

**WARNING:**

The unit must be disposed of through approved companies specialised in the identification of different types of materials (steel, copper, plastic, etc.).

---

---



---

**WARNING:**

It is prohibited to dispose of lubricating fluids and other hazardous substances in the environment.

---

# 10 Declarations

## 10.1 EC Declaration of Conformity (Original)

Xylem Service Italia S.r.l., with headquarters at Via Vittorio Lombardi 14 - 36075 Montecchio Maggiore VI - Italy, hereby declares that the product:

Close-coupled submersible pump unit

fulfils the relevant provisions of the following European Directives:

- 2006/42/EC Machines (ATTACHMENT II - physical or legal person authorised to compiling the technical folder: Xylem Service Italia S.r.l.)

and the following technical standards:

- EN 809:1998+A1:2009
- EN 60335-1:2012+A11:2014+A13:2017
- EN 60335-2-41:2003+A1:2004+A2:2010
- EN 62233:2008

Montecchio Maggiore, 10/09/2018

Amedeo Valente  
(Director of Engineering and R&D)



rev.00

## 10.2 EU Declaration of Conformity (n. EMCD36)

1. Apparatus model/Product:  
Close-coupled submersible pump unit
2. Name and address of the manufacturer:  
Xylem Service Italia S.r.l.  
Via Vittorio Lombardi 14  
36075 Montecchio Maggiore VI  
Italy
3. This declaration of conformity is issued under the sole responsibility of the manufacturer.
4. Object of the declaration:  
Close-coupled submersible pump unit
5. The object of the declaration described above is in conformity with the relevant Union harmonization legislation:  
2014/30/EU Directive of 26 February 2014 (electromagnetic compatibility)
6. References to the relevant harmonized standards used or references to the other technical specifications, in relation to which conformity is declared:  
EN 55014-1:2006+A1:2009+A2:2011, EN 55014-2:1997+A1:2001+A2:2008, EN 61000-3-2:2014, EN 61000-3-3:2013
7. Notified body: -
8. Additional information: -

Signed for and on behalf of: Xylem Service Italia S.r.l.

Montecchio Maggiore, 10/09/2018

Amedeo Valente  
(Director of Engineering and R&D)



rev.00



## 10.3 EU Declaration of Conformity (RoHS II)

1. AEE unique identification: N. SC
2. Name and address of the manufacturer:  
Xylem Service Italia S.r.l.  
Via Vittorio Lombardi 14  
36075 Montecchio Maggiore VI  
Italy
3. This declaration of conformity is issued under the sole responsibility of the manufacturer.
4. Object of the declaration:  
Close-coupled submersible pump unit
5. The object of the above declaration complies with the 2011/65/EU directive of the European Parliament and Council of 8 June 2011 on the restriction of use of certain dangerous substances in electric and electronic equipment, and with delegate directive (EU) 2015/863 of 31 March 2015 of the Commission.
6. References to the relevant harmonized standards used or references to the other technical specifications, in relation to which conformity is declared:  
EN 50581:2012
7. Additional information: -  
Attachment III - Exempt applications: 6(a)(b)(c)

Signed for and on behalf of: Xylem Service Italia S.r.l.

Montecchio Maggiore, 10/09/2018

Amedeo Valente  
(Director of Engineering and R&D)



rev.00

Lowara is a trademark of Xylem Inc. or one of its subsidiaries.

# 11 Warranty

## 11.1 Information

For information on the warranty refer to the documentation of the sale contract.



# Xylem |'zīləm|

- 1) The tissue in plants that brings water upward from the roots;
- 2) A leading global water technology company.

We're a global team unified in a common purpose: creating innovative solutions to meet our world's water needs. Developing new technologies that will improve the way water is used, conserved, and re-used in the future is central to our work. We move, treat, analyze, and return water to the environment, and we help people use water efficiently, in their homes, buildings, factories and farms. In more than 150 countries, we have strong, long-standing relationships with customers who know us for our powerful combination of leading product brands and applications expertise, backed by a legacy of innovation.

For more information on how Xylem can help you, go to [www.xylem.com](http://www.xylem.com)



Xylem Service Italia S.r.l.  
Via Vittorio Lombardi 14  
36075 - Montecchio Maggiore (VI) - Italy  
[www.xylem.com/brands/lowara](http://www.xylem.com/brands/lowara)

Lowara is a trademark of Xylem Inc. or one of its subsidiaries.  
© 2018 Xylem, Inc. Cod.001082030EN rev.B ed.03/2019