

## SCALA2



TM06 4538 2515

### General description

Grundfos SCALA2 is a fully integrated, self-priming, compact waterworks for pressure boosting in domestic applications.

SCALA2 incorporates integrated speed control enabling the keeping of the perfect pressure at the taps, meaning that the pump performance will increase with increasing demand.

SCALA2 can be installed in three easy steps:

1. Connect the pipes.
2. Prime the pump.
3. Plug the pump into the power outlet and the pump will start.

Grundfos SCALA2 has all the components necessary to ensure a comfortable pressure:

- intelligent controller
- integrated speed-controlled drive
- integrated tank
- integrated sensors
- integrated non-return valve.

### Features

<b>SCALA2</b>
Adjustable constant pressure
Low noise, < 47 dB(A) (in typical use)
Compact
Robust and reliable
Easy installation and self-priming
Dry-running protection

### Applications

Grundfos SCALA2 is designed for pressure boosting in one- and two-family houses and apartments.

We recommend SCALA2 for the following applications:

- pressure boosting of city mains water
- pressure boosting of water from roof tank
- pressure boosting of water from break tank
- pressure boosting of water from ground tank
- water supply from shallow wells (< 8 m).

### Performance

SCALA2 is suitable for houses with up to three floors and eight tapping points.

Accurate sizing of the pump can be based on the pump curve below and local norms and standards.

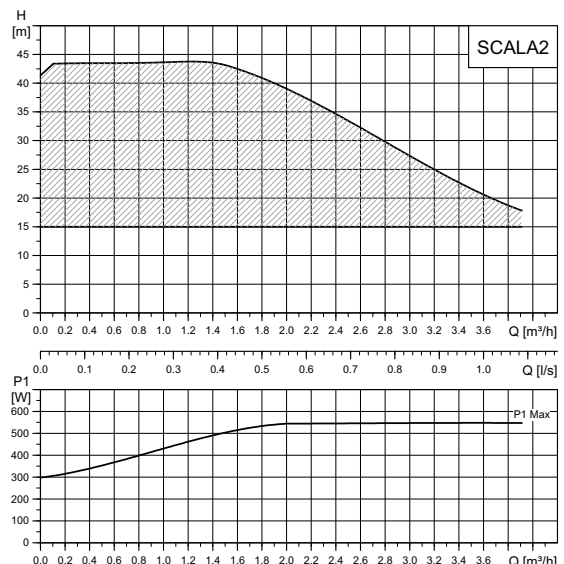

TM06 4320 1915

### Control panel

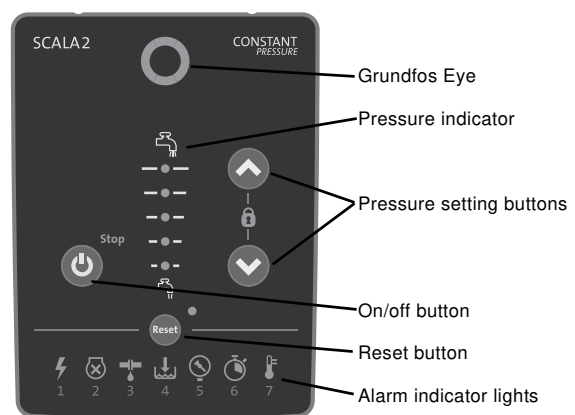

TM06 3301 5114

## Exploded view

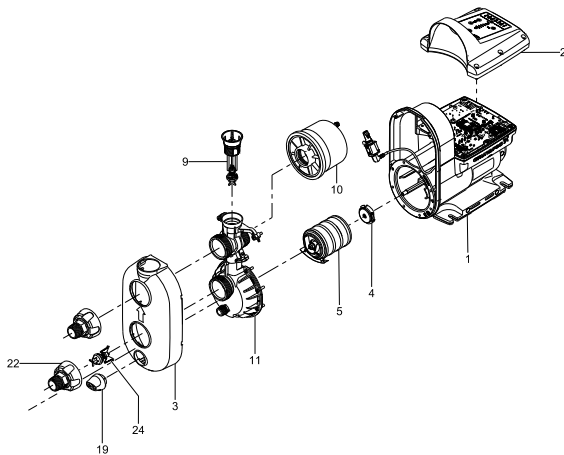

TM06 3306 5114

## Materials

Pos.	Component name	Material
1	Combined pump and stator housing	Aluminium, Composite and EN 1.4301 / AISI 304
2	Control box cover	Composite
3	Pump cover	Composite
4	Shaft seal	Carbon/Ceramic
5	Chamber stack (four stages)	Composite
9	Non-return valve, outlet	Composite
10	Tank complete	Composite, Butyl and EN 1.4301/AISI 304
11	Connection part	Composite
19	Drain plug	Composite
22	Thread R 1" / NPT 1"	Composite
24	Non-return valve, inlet	Composite

## Dimensional sketch

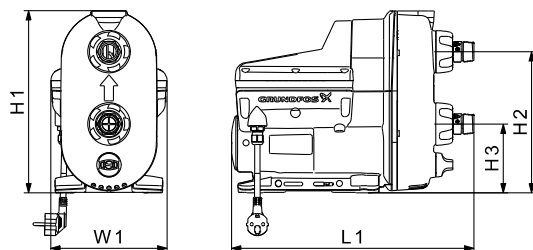

TM06 3305 5114

Type	H1 [mm] [inch]	H2 [mm] [inch]	H3 [mm] [inch]	W1 [mm] [inch]	L1 [mm] [inch]	Weight [kg] [lbs]
SCALA2	302 11.9	234 9.2	114 4.5	193 7.6	403 15.9	10 22

<b>98880509</b> 0915
ECM: 1166611

## Thermal protection

SCALA2 incorporates current- and temperature-dependent motor protection.

## Technical data

Type	Voltage [V] and Frequency [Hz]	I <sub>max</sub> [A] and P <sub>1</sub> [W]	Thread	Plug	Product number
SCALA2	1 x 200-240 50/60	2.3 - 2.8 550	R 1"	IEC type E & F, CEE7/7	98562862
				No plug (China)	98562863
				No plug	98562865
				IEC type I, AS/NZS3112	98562866
				IEC type G, BS1363	98562870
SCALA2	1 x 208-230 60	2.3 - 2.8 550	NPT 1"	IEC type I, IRAM 2073	98562872
				NEMA 6-15P	98562817
SCALA2	1 x 115 60	5 - 5.7 560		IEC type B, NEMA 5-15P	98562818

## Operating conditions

Max. ambient temperature: 45 °C (113 °F).  
55 °C (131 °F) for 1 x 200-240 V, 50 Hz models.

Max. liquid temperature: 45 °C (113 °F).

Max. system pressure: 10 bar (145 PSI, 1 MPa):

Max. inlet pressure: 6 bar (87 PSI, 0.6 MPa).

Max. head: 45 m (147 feet).0

IP rating: X4D (outdoor installation).

Pumped liquid: Clean, fresh water and chlorinated water < 300 ppm.

## Markings and approvals

Safety approvals



Drinking water approvals



Subject to alterations.