

SEG and SEG AUTO_{ADAPT}

0.9 to 4.0 kW
50 Hz

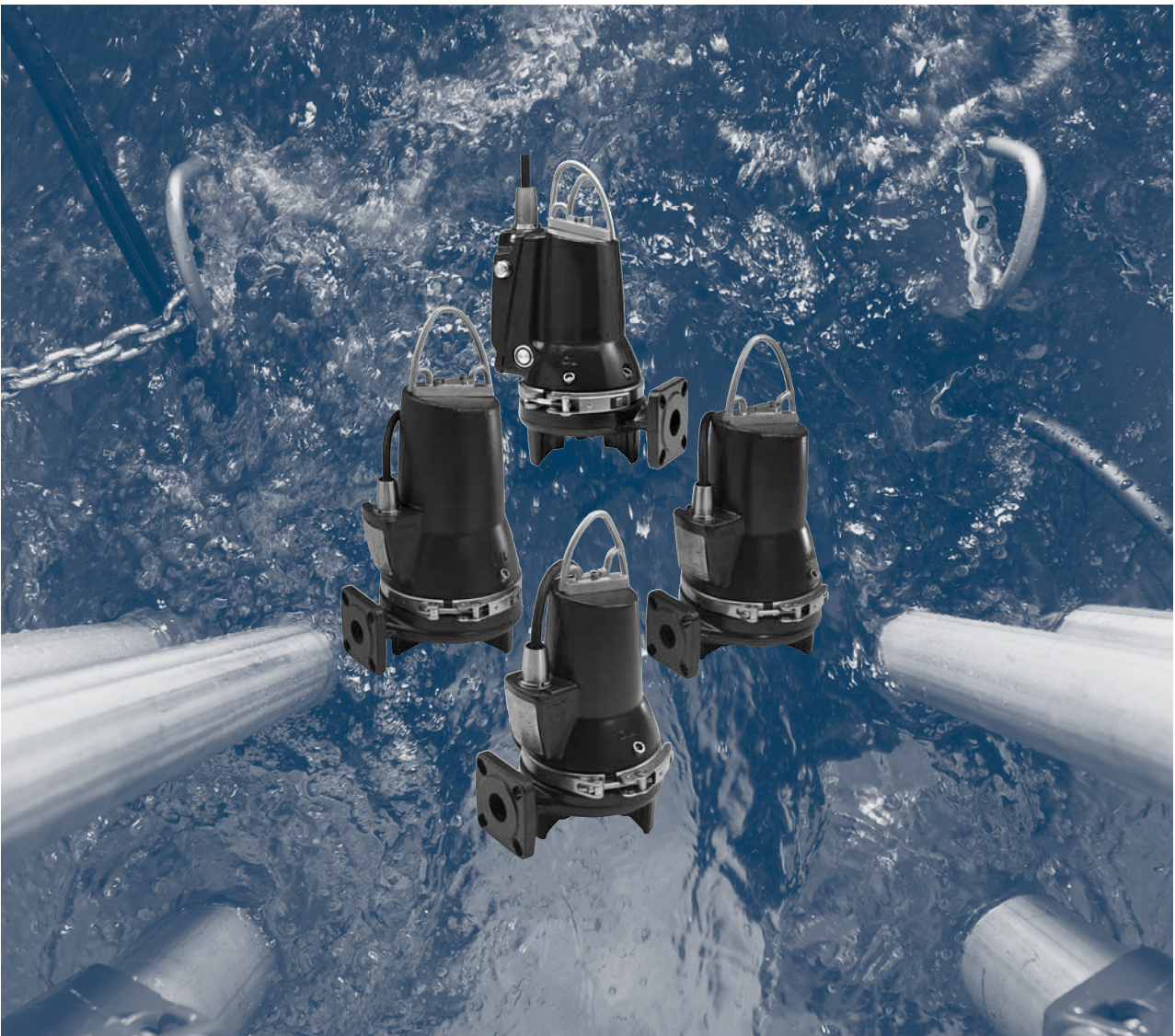

Contents

Introduction

Introduction	3
Applications	3
Construction features	4

Identification

Type key	5
Nameplates	6

Selection of product

Ordering a pump	8
-----------------	---

Performance range

Performance overview	9
----------------------	---

Product range

Product range	10
SEG pumps	10
Explosion-proof SEG pumps	10
SEG AUTO _{ADAPT} pumps	11
Explosion-proof SEG AUTO _{ADAPT} pumps	11

Variants

List of variants	12
------------------	----

Construction

Material specification, SEG pumps	14
Material specification, SEG AUTO _{ADAPT} pumps	19

Product description

Features	25
Operating conditions	26
Pumped liquids	26
Motor range	26
Frequency converter operation	26
Approvals	27
Wiring diagrams	28

Curve charts

Curve conditions	30
Performance tests	30
Certificates	30
Witness test	30

Performance curves/ Technical data

Performance curves, SEG.40.09.(E).(Ex).2.1.502	31
Electrical data	31
Pump data	31
Performance curves, SEG.40.09.(E).(Ex).2.50B/C	32
Electrical data	32
Pump data	32
Performance curves, SEG.40.12.(E).(Ex).2.1.502	33
Electrical data	33
Pump data	33
Performance curves, SEG.40.12.(E).(Ex).2.50B/C	34
Electrical data	34
Pump data	34
Performance curves, SEG.40.15.(E).(Ex).2.50B/C	35
Electrical data	35
Pump data	35
Performance curves, SEG.40.26.(E).(Ex).2.50B/C	36
Electrical data	36
Pump data	36
Performance curves, SEG.40.31.(E).(Ex).2.50B/C	37
Electrical data	37
Pump data	37
Performance curves, SEG.40.40.(E).(Ex).2.50B/C	38
Electrical data	38
Pump data	38

Dimensions

SEG pumps	39
SEG AUTO _{ADAPT} pumps	40

Accessories

Installation systems for SEG and SEG AUTO _{ADAPT} pumps	43
SEG pumps	44
SEG AUTO _{ADAPT} pumps	46

Further product documentation

WebCAPS	48
WinCAPS	49

Introduction

This data booklet deals with Grundfos SEG and SEG AUTO_{ADAPT} sewage pumps.



Fig. 1 SEG and SEG AUTO_{ADAPT} pumps

The SEG pumps are designed with a grinder system which grinds solids into small pieces so that they can be led away through discharge pipes of a relatively small diameter.

The pumps are made of wear-resistant materials, such as cast iron and stainless steel. These materials ensure reliable operation.

The pumps are available with motors of 0.9 kW and up to and including 4 kW.

The nominal diameter of the pump discharge port is 40 mm.

The pumps are available for

- submerged installation on auto-coupling system
- submerged installation, free-standing.

Applications

The SEG pumps are ideal for use in sparsely populated areas where gravity sewage systems are not available. Examples include small villages, farm areas, and areas with difficult topography, such as rocky terrains with large differences in levels, or any other area where a pressurised system offers advantages.

Construction features

All pumps have the following features:

- Cable connection to motor via plug.
- Watertight cable entry of corrosion-resistant polyamide.
- Clamp connection between motor and pump.
- Cartridge shaft seal.
- Heavy-duty bearings greased for life.
- Patented grinder system ensures extremely high efficiency and reliable operation.
- SmartTrim system enables quick and easy impeller clearance adjustment in order to maintain peak performance.
- Thermal switches built into the motor windings provide protection against overheating.
- Explosion-proof motors for potentially explosive environments.

Additional SEG AUTO_{ADAPT} features

The SEG AUTO_{ADAPT} pumps incorporate a controller, sensors and motor protection. They only need to be connected to the mains supply.

The pumps offer the following benefits:

- Built-in level and dry-running sensors.
- Built-in motor protection.
- Pump alternation.
If several pumps are installed in the same tank, the control logic incorporated in the pump will ensure that the load is distributed evenly among the pumps over time.
- Alarm relay output.
The pump incorporates an alarm relay output. NC and NO are available and can be used as required, for example for acoustic or visual alarms.

- Random start delay in case of general power shutdown.
- The pump does not start unless the phase sequence is correct.
- Self-calibration after each pump cycle.
- Anti-seizing function.
The anti-seizing function starts the pump at programmed intervals to prevent the impeller from seizing up. This function will overrule the dry-running sensor of non-Ex versions.
- After-run function (foam draining).
The after-run function can be used at programmed intervals if there is a risk of a floating layer.

The Grundfos CIU unit can be permanently or temporarily connected for changing the default settings, making further settings or reading the alarm log and operating parameters, such as number of starts and operating hours.

Alarm	Alarm log	Signal relay
Overvoltage	•	•
Undervoltage	•	•
Overload	•	•
Blocked motor/pump	•	•
Dry running	•	
Motor temperature	•	•
Electronics temperature (Pt1000)	•	•
Thermal switch 1 in motor	•	•
Thermal switch 2 in motor	•	•
Phase sequence reversed	•	•
High-level alarm		•
Sensor fault	•	•

Type key

The type key covers the entire range of Grundfos SEG and SEG AUTO_{ADAPT} wastewater pumps. Each SEG pump can be identified by means of the type key.

Code	Example	SE	G	.40	.11	E	.Ex	.2	.1	5	02
	Type range										
SE	Grundfos sewage pumps										
	Impeller type										
G	Grinder system in the pump inlet										
	Pump discharge										
40	Nominal diameter of discharge port [mm]										
	Output power, P2										
11	P2 = code number from type designation/10 [kW]										
	Equipment in pump										
Blank	Standard										
E	Electronic version with AUTO _{ADAPT} functions										
	Pump version										
Blank	Non-explosion-proof pump (standard)										
Ex	Explosion-proof pump										
	Number of poles										
2	2 poles, n = 3000 min ⁻¹ , 50 Hz										
	Number of phases										
1	Single-phase motor										
Blank	Three-phase motor										
	Mains frequency										
5	50 Hz										
	Supply voltage and starting method										
02	230 V, direct-on-line starting										
0B	400-415 V, direct-on-line starting										
0C	230-240 V, direct-on-line starting										
	Generation										
Blank	First generation										
A	Second generation										
B	Third generation, etc.										
	The pumps belonging to the individual generations differ in design, but are similar in terms of power rating.										
	Materials in pump										
Blank	Standard materials in pump										

Nameplates

The nameplate states the operating data and approvals applying to the pump.

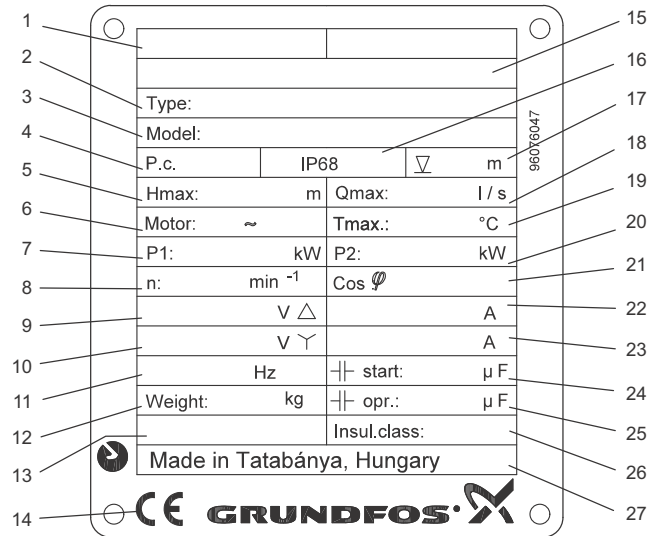
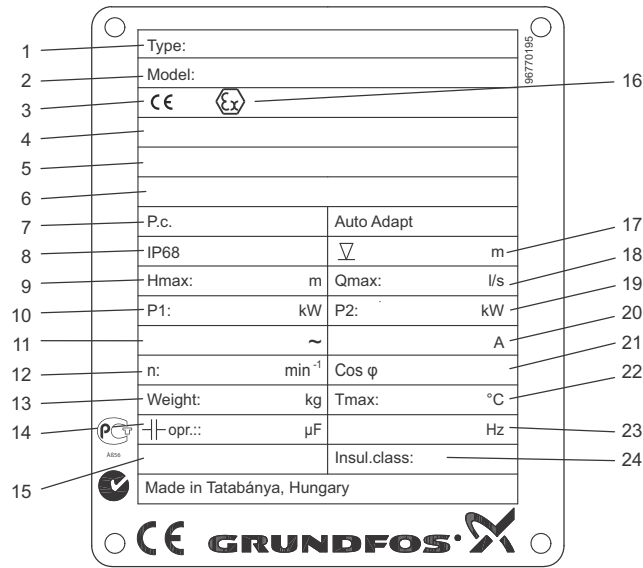

Fig. 2 SEG nameplate

Pos.	Description	Pos.	Description
1	Ex mark	15	Explosion protection
2	Type designation	16	Enclosure class to IEC
3	Product number	17	Maximum installation depth
4	Production code (year/week)	18	Maximum flow rate
5	Maximum head	19	Maximum liquid temperature
6	Number of phases	20	Output power
7	Rated input power	21	Power factor
8	Rated speed	22	Rated current, Δ
9	Rated voltage, Δ	23	Rated current, Y
10	Rated voltage, Y	24	Starting capacitor
11	Frequency	25	Operating capacitor
12	Weight without cable	26	Insulation class
13	EN approval	27	Country of production
14	CE mark		

TM04 6534 0510



TM04 4459 5209

Fig. 3 SEG AUTO_{ADAPT} nameplate

Pos.	Description	Pos.	Description
1	Type designation	13	Weight without cable
2	Product number	14	Operating capacitor
3	CE mark	15	EN approval
4	ATEX certificate*	16	Ex mark*
5	IEC Ex mark*	17	Maximum installation depth
6	IEC Ex certificate*	18	Maximum flow rate
7	Production code (year/week)	19	Output power
8	Enclosure class to IEC	20	Rated current
9	Maximum head	21	Power factor
10	Rated input power	22	Maximum liquid temperature
11	Number of phases	23	Frequency
12	Rated speed	24	Insulation class

* Only explosion-proof pumps.

Ordering a pump

When ordering a pump, you need to take the following aspects into consideration:

- pump type
- custom-built variation (option)
- accessories
- controller
- explosion-proof version.

Pump type

When you have selected the pump type, you can identify the specific pump that best meets your needs in sections *Product range*, page 10, and *Type key*, page 5.

The list below is a detailed description of the product you get if you order the following pump:

Pump	Product number
SEG.40.09.2.1.502	96075893
<ul style="list-style-type: none">• Pump as specified in the type key.• 10 metres of cable.• Paint: NSC 8005-R80B (dark grey), gloss code 35, thickness 100 µ.• Thermal switches built into the motor windings.• Tested according to DIN 9906, Annex A.	

See section *Performance curves/ Technical data*, page 31, for selection of a pump.

Note: Pump-specific data can also be found on www.Grundfos.com (WebCAPS) by entering the product number 96075893.

For further information about WebCAPS, see page 49.

Custom-built variants

The pumps can be customised to meet individual requirements. Many pump features and options are available for customisation, such as explosion-proof versions, cable lengths or special materials.

Accessories

Depending on installation type and pump variant, accessories may be required. See section *Accessories*, page 43, for selection of the correct accessories.

Note: Ordered accessories are not fitted from factory.

Controller

The following controllers are available:

SEG

- Dedicated Controls. See also page 44.
- LC and LCD 107 operated by air bells. See also page 45.
- LC and LCD 108 operated by float switches. See also page 45.
- LC and LCD 110 operated by electrodes. See also page 45.
- CU 100. See also page 46.

SEG AUTO_{ADAPT}

- Built-in controller. See also page 4.
- Grundfos CIU unit. See also page 47.
- Grundfos R100 remote control. See also page 47.

Explosion-proof version

Both pump ranges are available in explosion-proof versions.

SEG and SEG AUTO_{ADAPT}

The pumps are provided with a Europe CE 0344  II 2G and Ex bcd IIB T4 Gb explosion protection classification according to EN 12050-1 and EN 12050-2.

The pumps are also available for IEC countries (Australia and others) with an Ex d IIB T4 Gb explosion protection classification according to IEC 60079-0 and IEC 60079-1.

Performance overview

Figure 4 shows the performance range of SEG and SEG AUTO_{ADAPT} pumps as well as the explosion-proof versions. It gives an overview of the various sizes and impeller types.

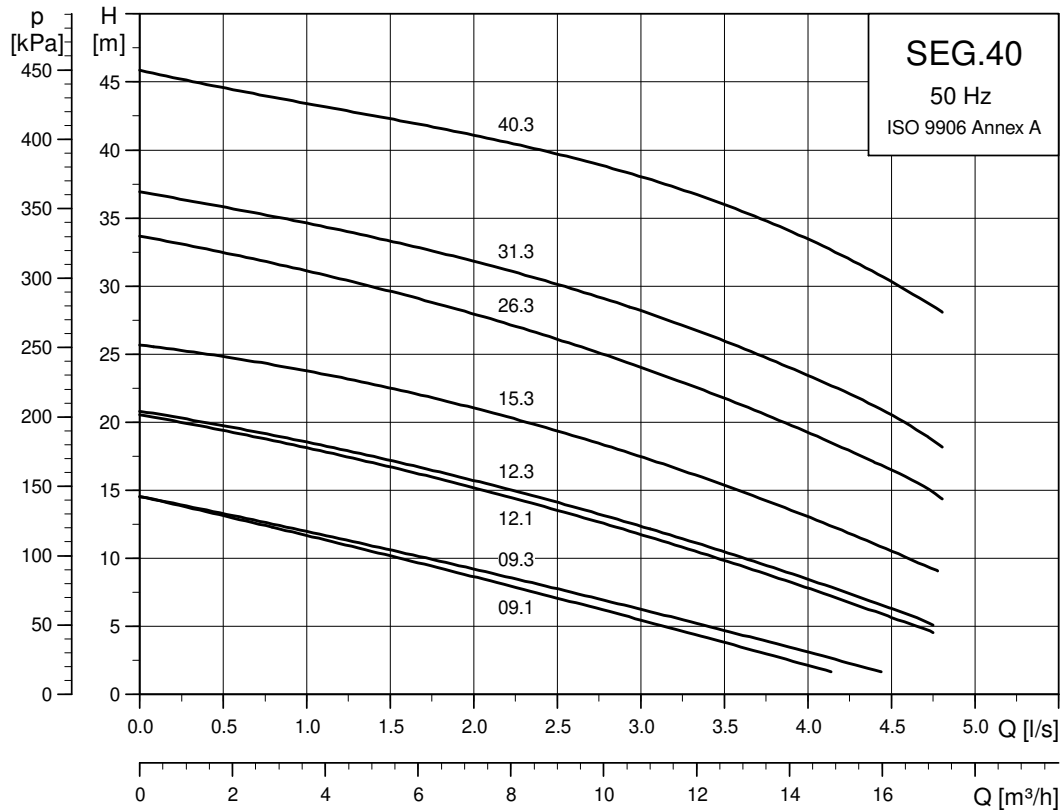

TM02 5265 2502

Fig. 4 Performance range

Channel-impeller pumps	Curve number
SEG.40.09.2.1.502	09.1
SEG.40.09.2.50B/C	09.3
SEG.40.12.2.1.502	12.1
SEG.40.12.2.50B/C	12.3
SEG.40.15.2.50B/C	15.3
SEG.40.26.2.50B/C	26.3
SEG.40.31.2.50B/C	31.3
SEG.40.40.2.50B/C	40.3

Product range

SEG pumps

Pump type	Supply voltage [V]	Starting method	Cable length [m]	Thermal protection	Product number
SEG.40.09.2.1.502	1 x 230	DOL	10	Thermal switch	96075893
SEG.40.09.2.50C	3 x 230-240	DOL	10	Thermal switch	96075919
SEG.40.09.2.50B	3 x 400-415	DOL	10	Thermal switch	96075897
SEG.40.12.2.1.502	1 x 230	DOL	10	Thermal switch	96075901
SEG.40.12.2.50C	3 x 230-240	DOL	10	Thermal switch	96075920
SEG.40.12.2.50B	3 x 400-415	DOL	10	Thermal switch	96075905
SEG.40.15.2.50C	3 x 230-240	DOL	10	Thermal switch	96075921
SEG.40.15.2.50B	3 x 400-415	DOL	10	Thermal switch	96075909
SEG.40.26.2.50C	3 x 230-240	DOL	10	Thermal switch	96075922
SEG.40.26.2.50B	3 x 400-415	DOL	10	Thermal switch	96075913
SEG.40.31.2.50C	3 x 230-240	DOL	10	Thermal switch	96075923
SEG.40.31.2.50B	3 x 400-415	DOL	10	Thermal switch	96075915
SEG.40.40.2.50C	3 x 230-240	DOL	10	Thermal switch	96075924
SEG.40.40.2.50B	3 x 400-415	DOL	10	Thermal switch	96075917

Explosion-proof SEG pumps

Pump type	Supply voltage [V]	Starting method	Cable length [m]	Thermal protection	Product number
SEG.40.09.Ex.2.1.502	1 x 230	DOL	10	Thermal switch	96075894
SEG.40.09.Ex.2.1.502	1 x 230	DOL	10	Thermal switch	96076161
SEG.40.09.Ex.2.50B	3 x 400	DOL	10	Thermal switch	96075898
SEG.40.09.Ex.2.50B	3 x 400-415	DOL	10	Thermal switch	96076162
SEG.40.12.Ex.2.1.502	1 x 230	DOL	10	Thermal switch	96075902
SEG.40.12.Ex.2.1.502	1 x 230	DOL	10	Thermal switch	96076163
SEG.40.12.Ex.2.50B	3 x 400	DOL	10	Thermal switch	96075906
SEG.40.12.Ex.2.50B	3 x 400-415	DOL	10	Thermal switch	96076164
SEG.40.15.Ex.2.50B	3 x 400	DOL	10	Thermal switch	96075910
SEG.40.15.Ex.2.50B	3 x 400-415	DOL	10	Thermal switch	96076165
SEG.40.26.Ex.2.50B	3 x 400	DOL	10	Thermal switch	96075914
SEG.40.26.Ex.2.50B	3 x 400-415	DOL	10	Thermal switch	96076166
SEG.40.31.Ex.2.50B	3 x 400	DOL	10	Thermal switch	96075916
SEG.40.31.Ex.2.50B	3 x 400-415	DOL	10	Thermal switch	96076167
SEG.40.40.Ex.2.50B	3 x 400	DOL	10	Thermal switch	96075918
SEG.40.40.Ex.2.50B	3 x 400-415	DOL	10	Thermal switch	96076168

For accessories, see section *Accessories*, page 43.

SEG AUTO_{ADAPT} pumps

Pump type	Supply voltage [V]	Starting method	Cable length [m]	Thermal protection	Product number
SEG.40.09.E.2.1.502	1 x 230	DOL	10	Thermal switch	96878505
SEG.40.09.E.2.50B	3 x 400-415	DOL	10	Thermal switch	96878506
SEG.40.12.E.2.1.502	1 x 230	DOL	10	Thermal switch	96878509
SEG.40.12.E.2.50B	3 x 400-415	DOL	10	Thermal switch	96878510
SEG.40.15.E.2.50B	3 x 400-415	DOL	10	Thermal switch	96878514
SEG.40.26.E.2.50B	3 x 400-415	DOL	10	Thermal switch	96878516
SEG.40.31.E.2.50B	3 x 400-415	DOL	10	Thermal switch	96878518
SEG.40.40.E.2.50B	3 x 400-415	DOL	10	Thermal switch	96878520

Explosion-proof SEG AUTO_{ADAPT} pumps

Pump type	Supply voltage [V]	Starting method	Cable length [m]	Thermal protection	Product number
SEG.40.09.E.Ex.2.1.502	1 x 230	DOL	10	Thermal switch	96878507
SEG.40.09.E.Ex.2.50B	3 x 400	DOL	10	Thermal switch	96878508
SEG.40.12.E.Ex.2.1.502	1 x 230	DOL	10	Thermal switch	96878512
SEG.40.12.E.Ex.2.50B	3 x 400	DOL	10	Thermal switch	96878513
SEG.40.15.E.Ex.2.50B	3 x 400	DOL	10	Thermal switch	96878515
SEG.40.26.E.Ex.2.50B	3 x 400	DOL	10	Thermal switch	96878517
SEG.40.31.E.Ex.2.50B	3 x 400	DOL	10	Thermal switch	96878519
SEG.40.40.E.Ex.2.50B	3 x 400	DOL	10	Thermal switch	96878521

For accessories, see section *Accessories*, page 43.

List of variants

Motor		
		15 m
		20 m
Standard cables	Cable B, 4 G 1.5 mm ² + 3 x 1 mm ²	25 m
		30 m
		40 m
		50 m
		15 m
Ex cables	Cable B, 4 G 1.5 mm ² + 3 x 1 mm ² , Ex	20 m
		25 m
		30 m
		40 m
		50 m
Screened power cables for frequency converters	Screened cable B, Ex	10 m
		15 m
		20 m
		25 m
		30 m
		40 m
Cable protection	For 7-core cable	
Special motor	Special voltage	
	With or without PTC, etc.	

Tests

Test at specified duty on standard impeller curve		
Trimmed impeller for specified duty test		
Additional test of entire QH curve (including report)	5 to 10 flows from pump performance curve.	
Different test standard	Efficiency guaranteed by Grundfos.	ISO 9906 grade 1 tolerances. ISO 9906 grade 2 tolerances.
Vibration test (including report)	According to Grundfos factory quality standard.	
NPSHr test	Not yet available.	
String test	Contact Grundfos.	
Witness test	Contact Grundfos.	

Certificates

ATEX-approved pump report	Special Grundfos report. Contact Grundfos.	
Certificate of compliance with order	According to EN 10204 2.1.	According to Annex A grades 1 and 2.
Pump certificate	According to EN 10204 2.2.	According to Annex A grades 1 and 2.
Inspection certificate	According to EN 10204 3.1.	According to Annex A grades 1 and 2.
Material specification report	According to EN 10204 3.1B.	
Material report with certificate	According to EN 10204 3.2.	Material supplier information.
Inspection certificate Lloyds Register	According to EN 10204 3.2.	
Inspection certificate DNV (Det Norske Veritas)	According to EN 10204 3.2.	
Inspection certificate Germanischer Lloyd	According to EN 10204 3.2.	
Inspection certificate American Bureau of Shipping	According to EN 10204 3.2.	
Inspection certificate Bureau Veritas	According to EN 10204 3.2.	
Registro Italiano Navale Argenteure	According to EN 10204 3.2.	
Other 3rd party test certificate	Contact Grundfos.	

Miscellaneous

Special packaging	Contact Grundfos.
Special nameplate	Contact Grundfos.
Other variants	Contact Grundfos.
Chemical-resistant shaft seal	FKM, standard (NBR).
Chemical-resistant pump	FKM, standard (NBR).
Internal surface treatment	Ceramic coating (impeller and pump housing). Extra epoxy (CED) coating.
Top coating	Black (RAL 9005), red (RAL 3000). Other colour.

Material specification, SEG pumps

The position numbers in the table below refer to the sectional drawings and exploded views on the following pages.

Pos.	Description	Material	EN standard	AISI/ASTM
6a	Pin	Stainless steel		
7a	Rivet	Stainless steel		
9a	Key	Stainless steel		
37a	O-rings	NBR		
44	Grinder ring	Stainless steel	1.4542	630
45	Grinder head	Stainless steel	1.4542	630
48	Stator			
49	Impeller	Cast iron	EN-JL-1030	
50	Pump housing	Cast iron	EN-JL-1030	
55	Stator housing	Cast iron	EN-JL-1030	
58	Shaft seal carrier	Cast iron	EN-JL-1030	
66	Locking ring	Stainless steel		
68	Adjusting nut	Stainless steel	1.4057	431
76	Nameplate	Stainless steel	1.4301	304
92	Clamp	Stainless steel	1.4301	304
102	O-ring	NBR		
103	Bush	Stainless steel	1.4057	431
104	Seal ring	NBR		
105	Shaft seal	Primary seal (0.9 to 1.5 kW): SiC/SiC Secondary seal (0.9 to 1.5 kW): lip seal, NBR Primary seal (2.6 to 4.0 kW): SiC/SiC Secondary seal (2.6 to 4.0 kW): carbon/aluminium oxide Other components: NBR, stainless steel		
107	O-rings	NBR		
112a	Retaining ring	Stainless steel		
150a	Stator in housing complete			
153	Bearing	Up to and including 1.5 kW: 6303 2.6 kW and up: 3205		
153a	Spacer ring	Stainless steel		
153b				
154	Bearing	Up to and including 1.5 kW: 6201 2.6 kW and up: 6205		
155	Oil chamber			
158	Corrugated spring	Steel		
159	O-ring	NBR		
172	Rotor/shaft	Shaft part at rotor: steel Shaft end at hydraulics: stainless steel	1.0533 1.4301	304
173	Screw	Steel		
173a	Washer	Steel		
176	Inner plug part	PET		
181	Outer plug part	CR rubber, cable H07RN-F	1.4308	CF-8
188a	Screw	Stainless steel		
190	Lifting bracket	Stainless steel	1.4308	CF-8
193	Oil screw	Stainless steel		
193a	Oil	Shell Ondina 913		
194	Gasket	Nylon		
195	Lock washer	Stainless steel		
198	O-ring	NBR		
	Paint	Two-component epoxy		

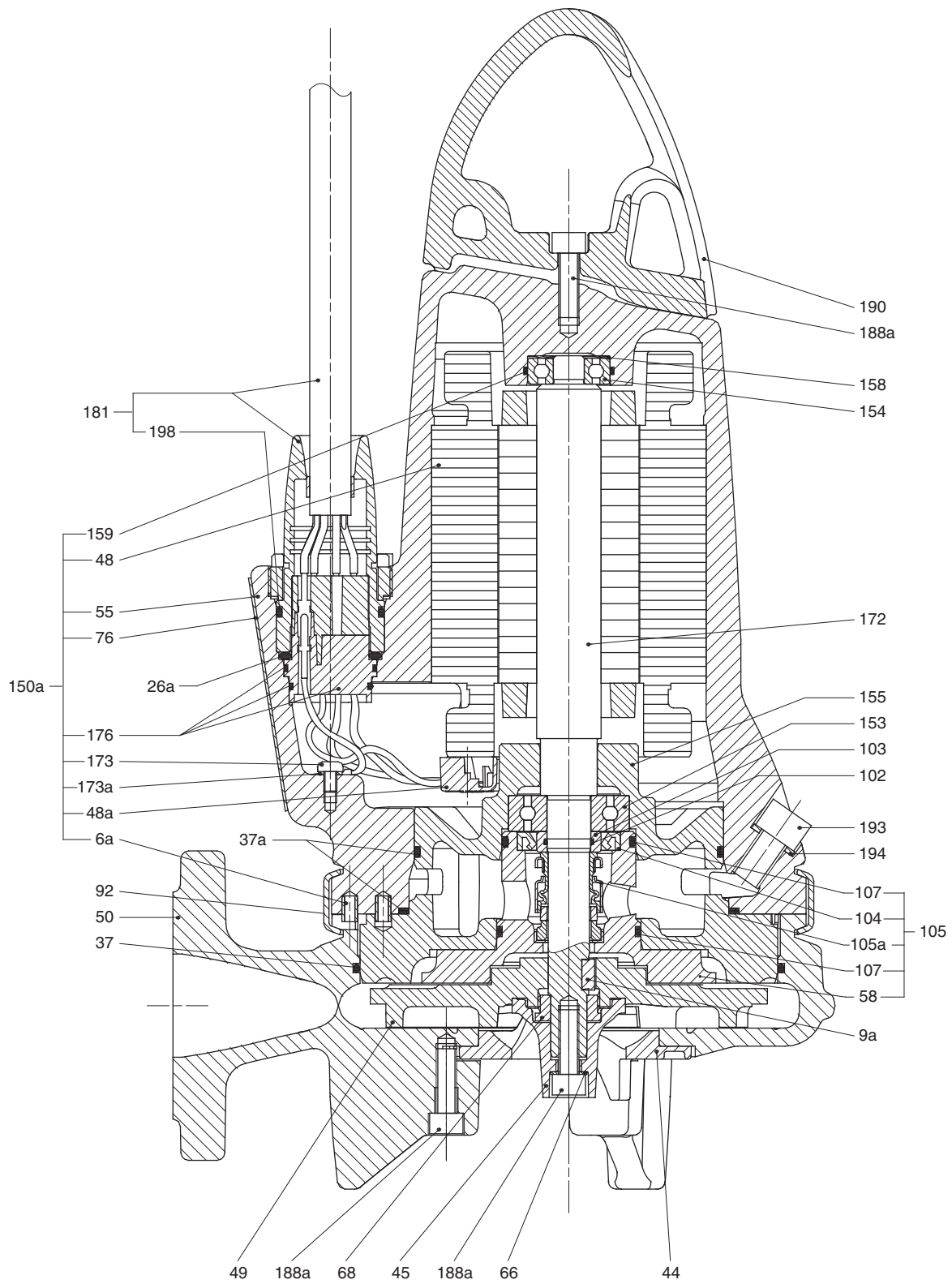

Fig. 5 Sectional drawing of SEG pumps, 0.9, 1.2 and 1.5 kW

TM02 5378 2802

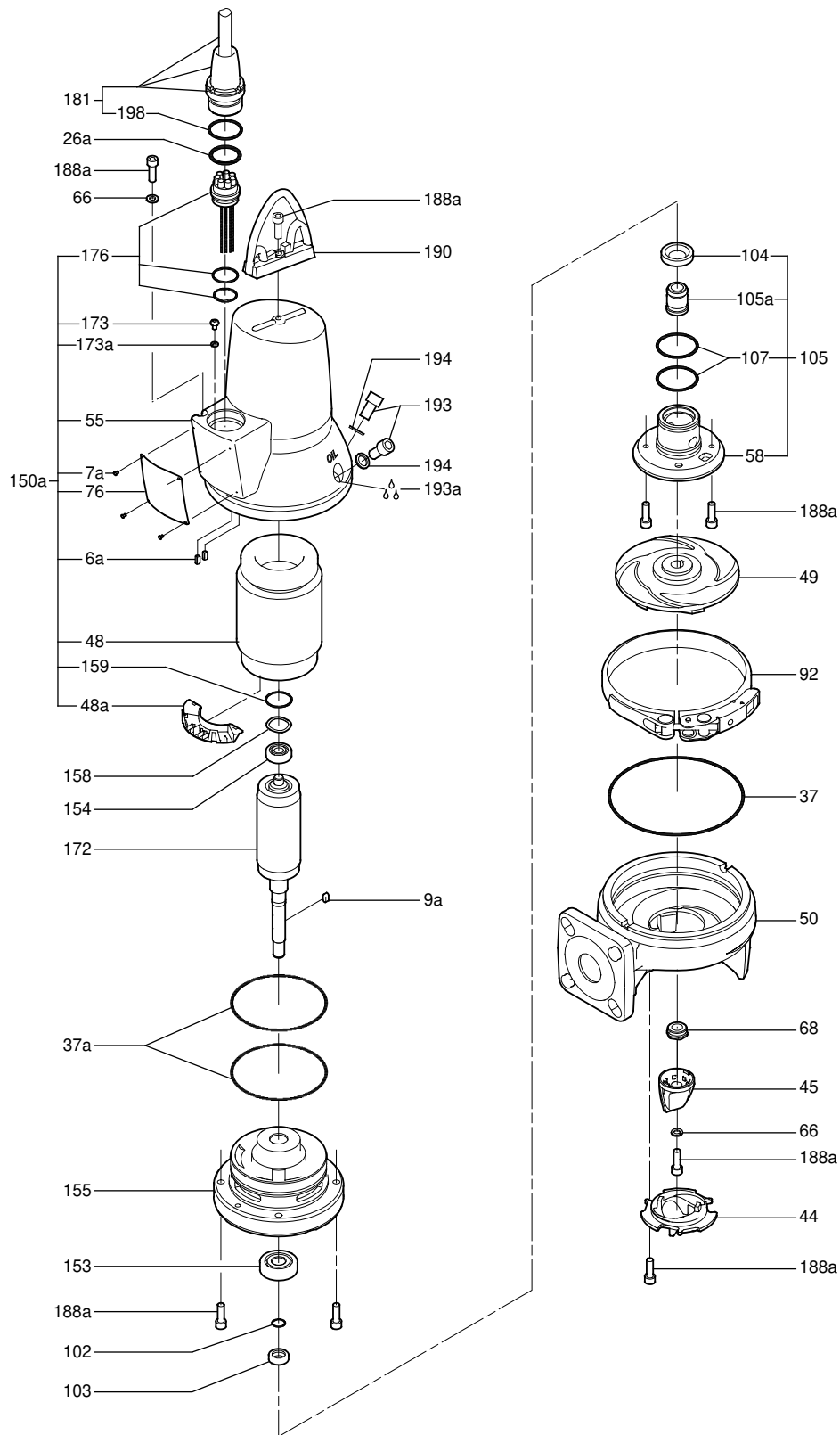
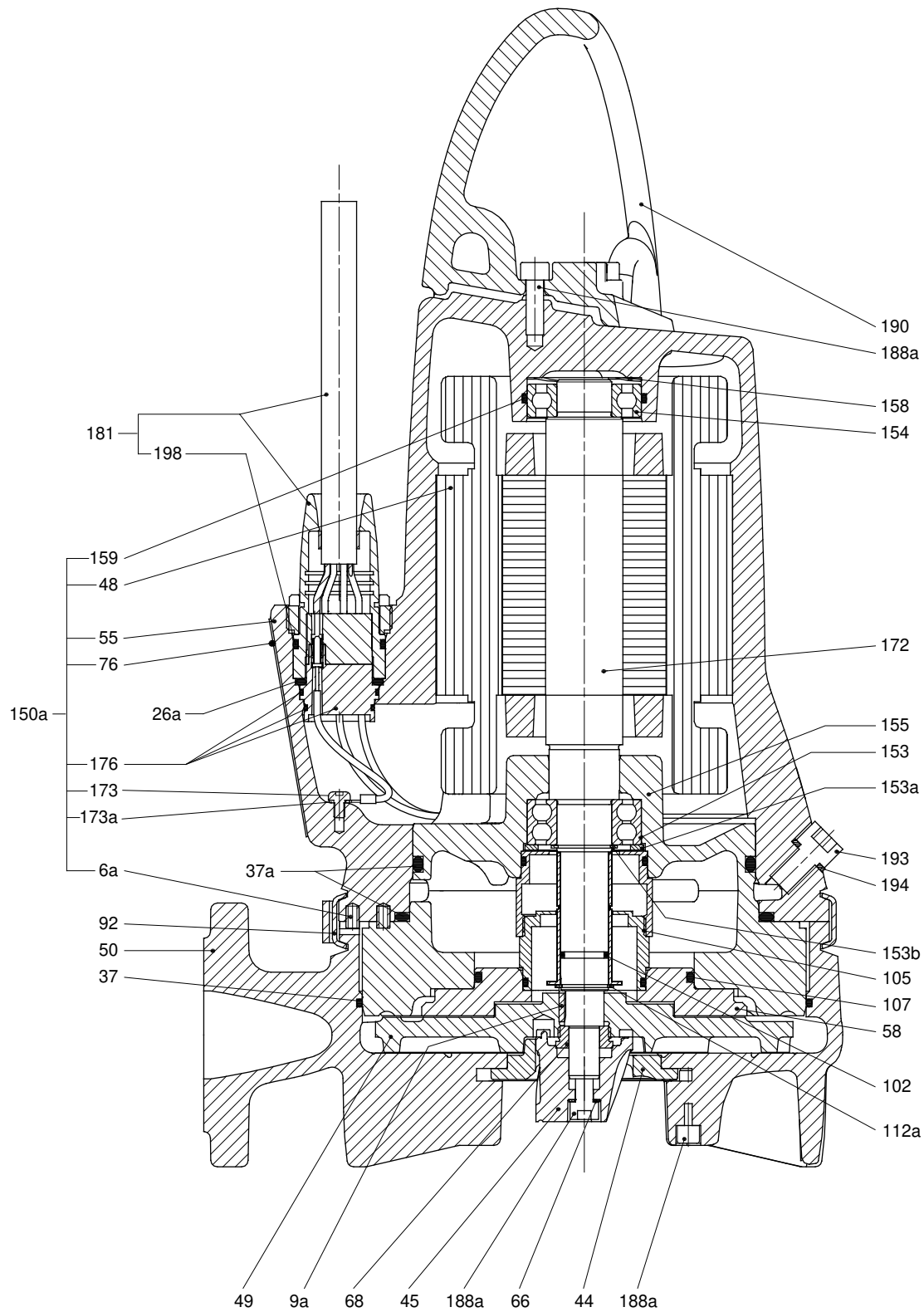

Fig. 6 Exploded view of SEG pumps, 0.9, 1.2 and 1.5 kW

TM02 5377 2802



TM02 5408 2804

Fig. 7 Sectional drawing of SEG pumps, 2.6, 3.1 and 4.0 kW

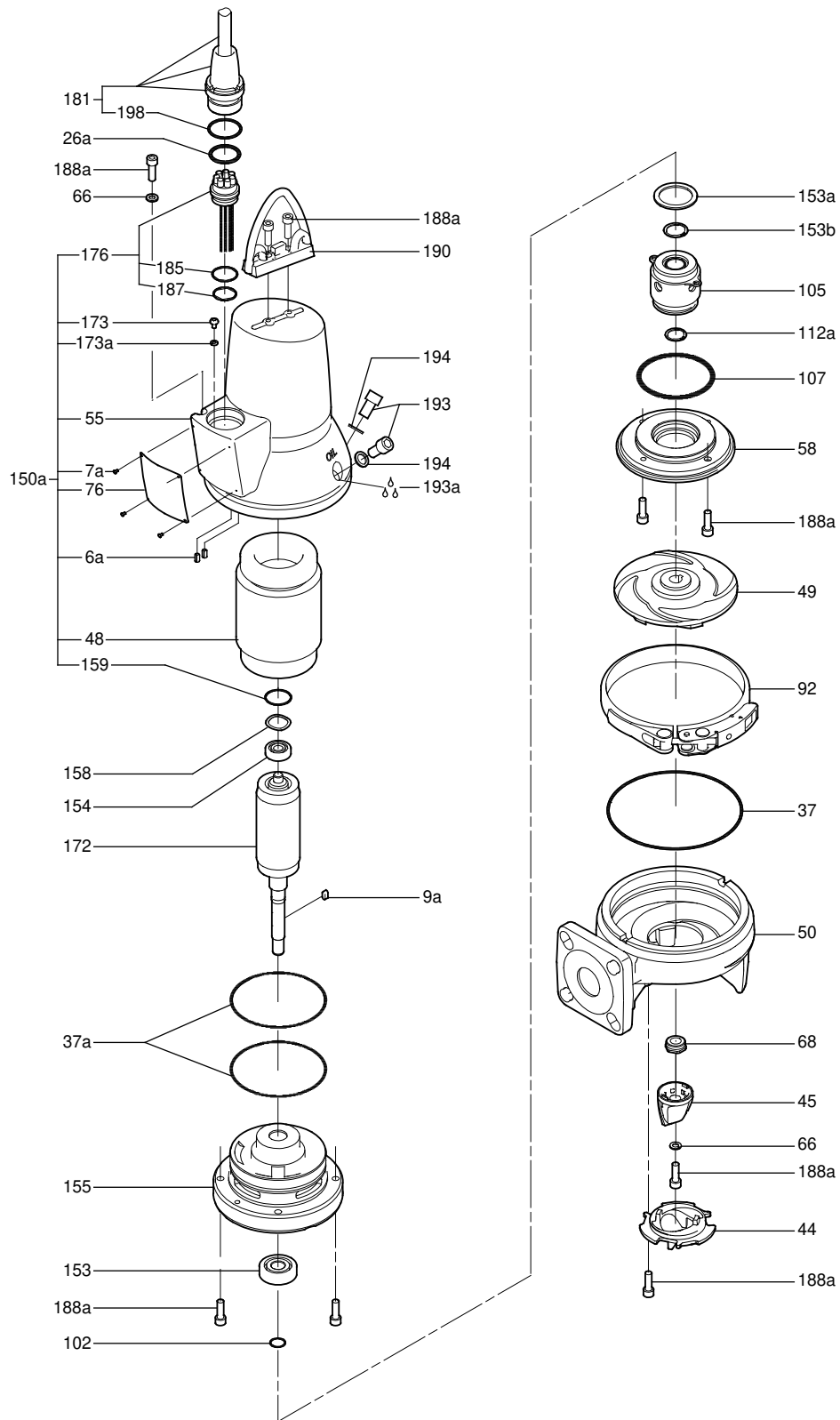

Fig. 8 Exploded view of SEG pumps, 2.6, 3.1 and 4.0 kW

TM02 5407 2804

Material specification, SEG AUTO_{ADAPT} pumps

The position numbers in the table below refer to the sectional drawings and exploded views on the following pages.

Pos.	Description	Material	EN standard	AISI/ASTM
6a	Pin	Stainless steel		
7a	Rivet	Stainless steel		
9a	Key	Stainless steel		
37a	O-rings	NBR		
44	Grinder ring	Stainless steel	1.4542	630
45	Grinder head	Stainless steel	1.4542	630
48	Stator			
48a	Terminal board			
49	Impeller	Cast iron	EN-JL-1030	
50	Pump housing	Cast iron	EN-JL-1030	
55	Stator housing	Cast iron	EN-JL-1030	
58	Shaft seal carrier	Cast iron	EN-JL-1030	
66	Locking ring	Stainless steel		
68	Adjusting nut	Stainless steel	1.4057	431
76	Nameplate	Stainless steel	1.4301	304
90a	Electronic unit			
90b	O-ring			
92	Clamp	Stainless steel	1.4301	304
102	O-ring	NBR		
103	Bush	Stainless steel	1.4057	431
104	Seal ring	NBR		
105/105a	Shaft seal	Primary seal (0.9 to 1.5 kW): SiC/SiC Secondary seal (0.9 to 1.5 kW): lip seal, NBR Primary seal (2.6 to 4.0 kW): SiC/SiC Secondary seal (2.6 to 4.0 kW): carbon/aluminium oxide Other components: NBR, stainless steel		
107	O-rings	NBR		
112a	Retaining ring	Stainless steel		
153	Bearing	Up to and including 1.5 kW: 6303 2.6 kW and up: 3205		
154	Bearing	Up to and including 1.5 kW: 6201 2.6 kW and up: 6205		
155	Oil chamber			
158	Corrugated spring	Steel		
159	O-ring	NBR		
161	Operating capacitor*			
161b	Nut			
161c	Bracket			
161d	Washer			
161e	Washer			
172	Rotor/shaft	Shaft part at rotor: steel Shaft end at hydraulics: stainless steel	1.0533 1.4301	304
173	Screw	Steel		
173a	Washer	Steel		
174	Earth screw			
174a	Washer			
176	Inner plug part	PET		
181	Outer plug part	CR rubber, cable H07RN-F	1.4308	CF-8
188a	Screw	Stainless steel		
190	Lifting bracket	Stainless steel	1.4308	CF-8
193	Oil screw	Stainless steel		
193a	Oil	Shell Ondina 913		
194	Gasket	Nylon		
198	O-ring	NBR		
285	Dry-running sensors**			
285a	O-ring	NBR	1.4308	CF-8
285b	Set screw			

Pos.	Description	Material	EN standard	AISI/ASTM
287	Level sensor			
287a	Protection cap			
287b	O-ring			
287c	Set screw			
288	Pt1000 sensor			
	Paint	Two-component epoxy		

* Single-phase pumps only.

** Explosion-proof pumps have two dry-running sensors.

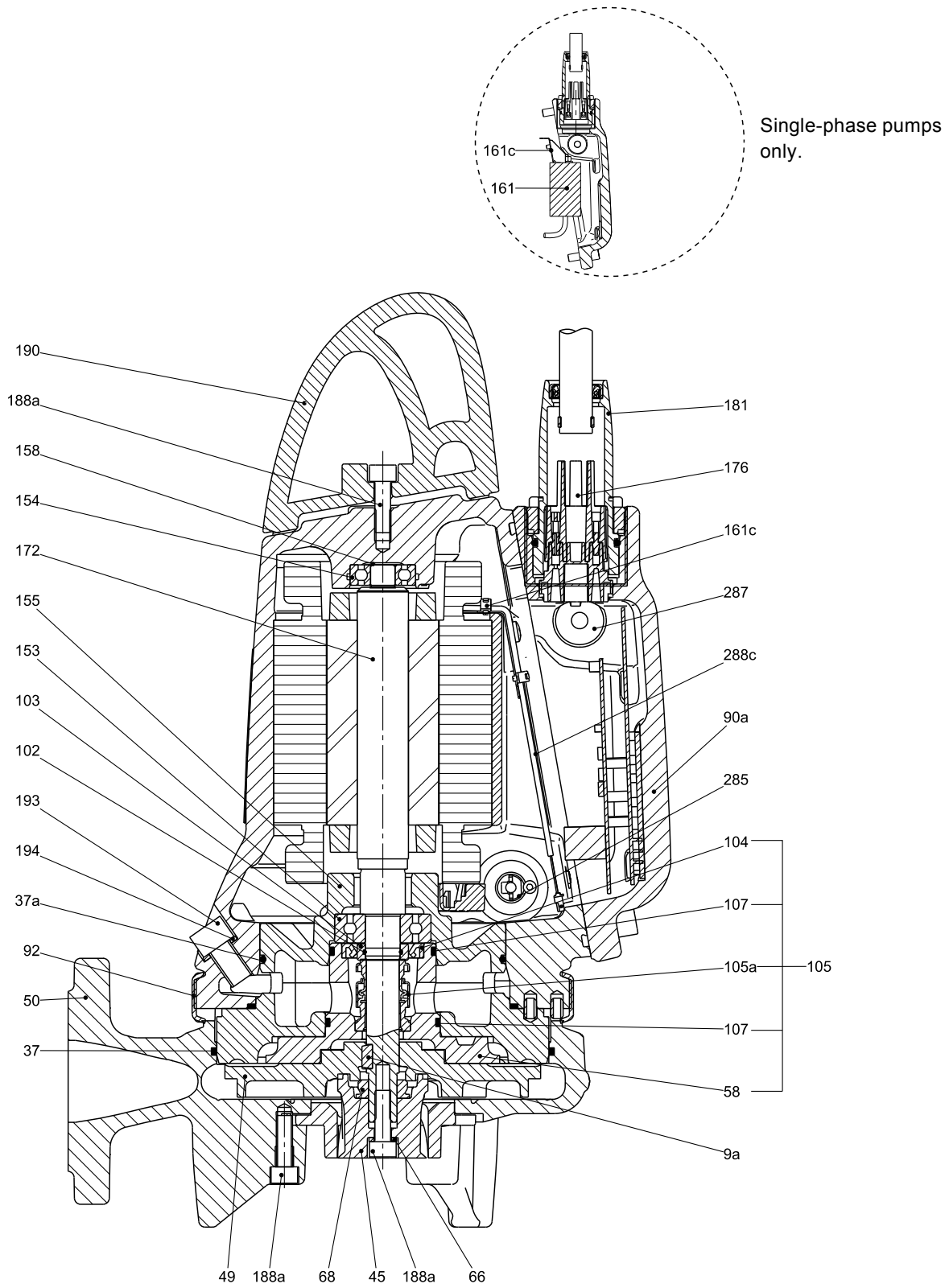

Fig. 9 Sectional drawing of SEG AUTO_{ADAPT} pumps, 0.9, 1.2 and 1.5 kW

TM04 6007 4609

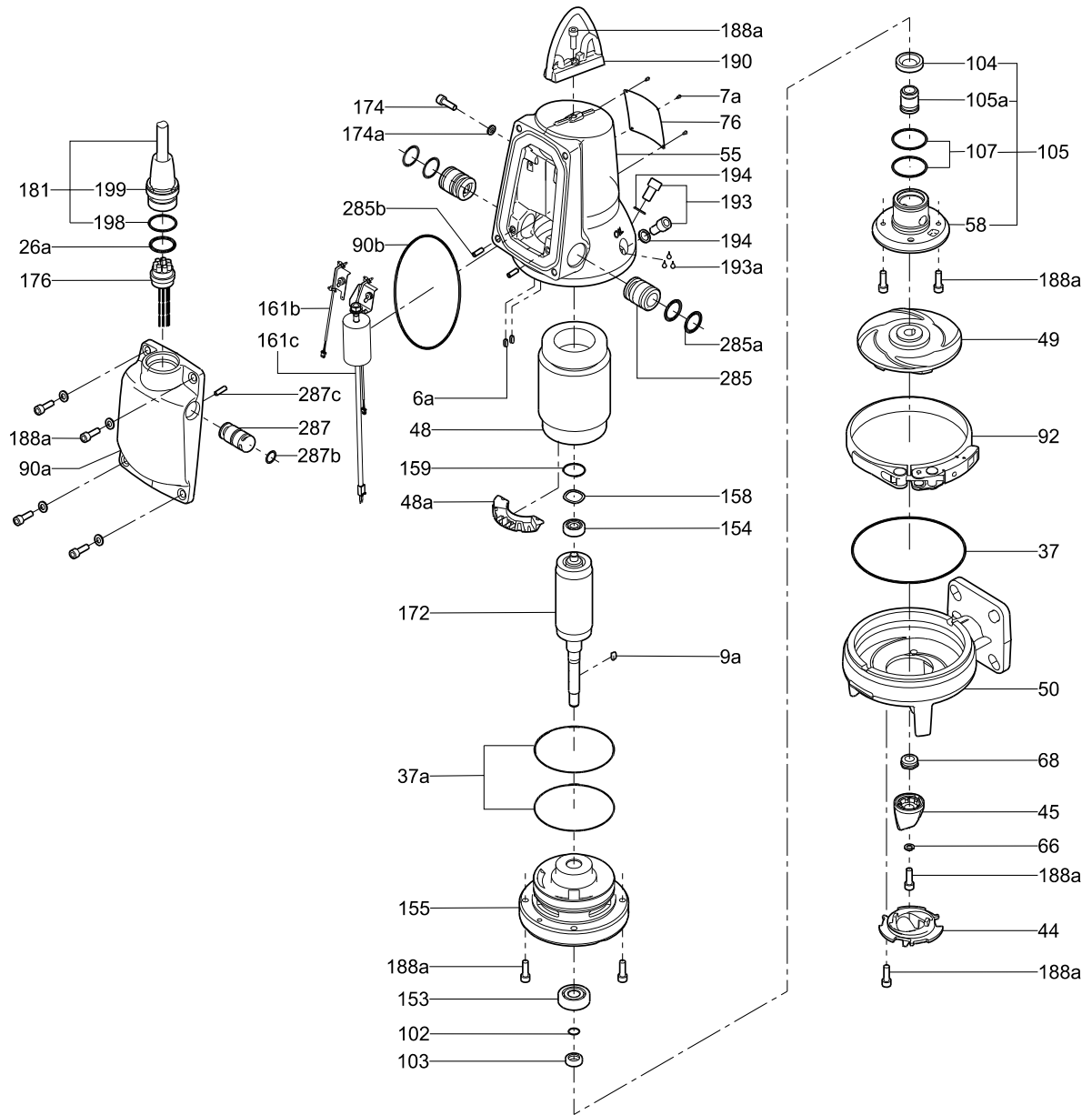
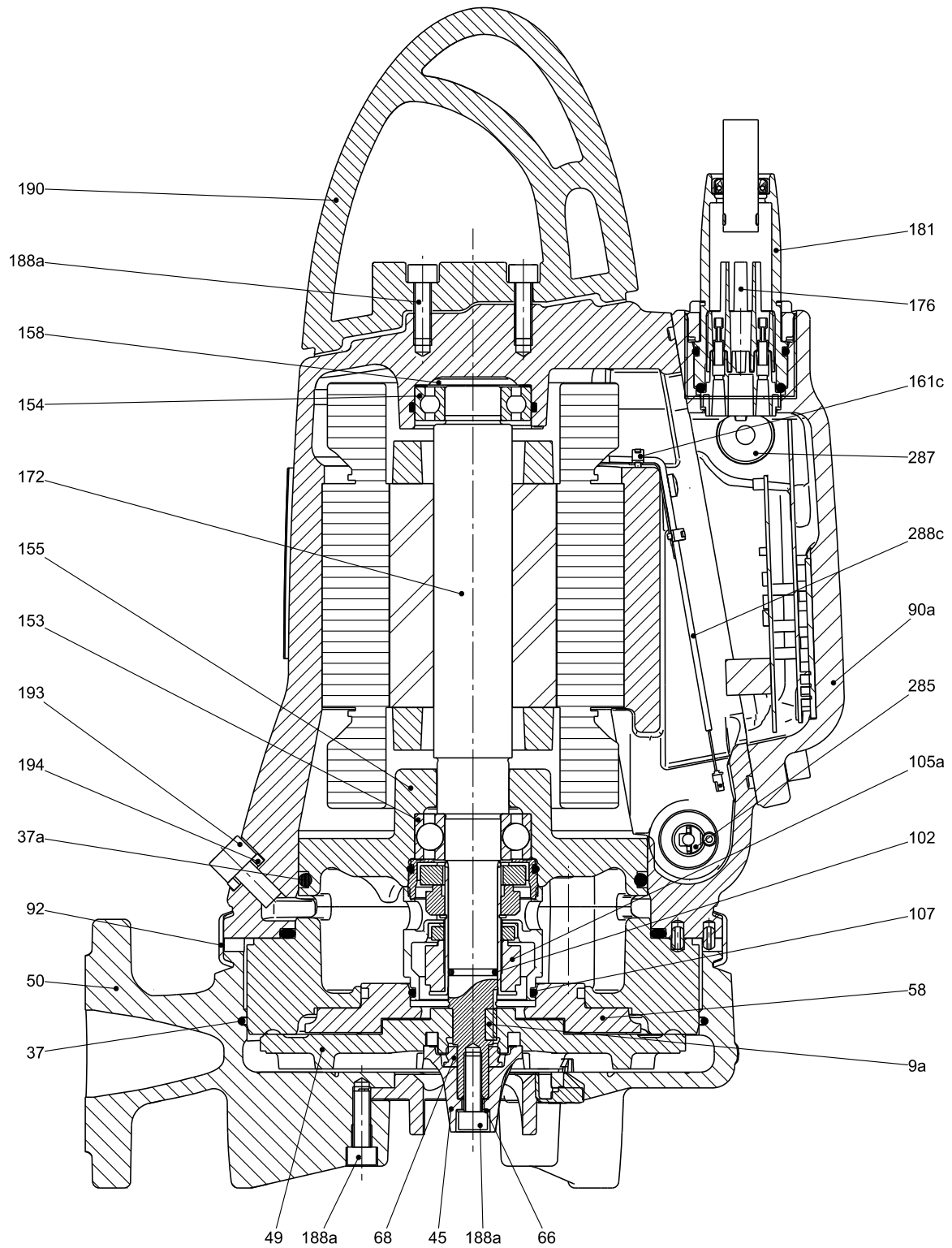

Fig. 10 Exploded view of SEG AUTO_{ADAPT} pumps, 0.9, 1.2 and 1.5 kW

TM04 4486 1909



TM04 5988 4609

Fig. 11 Sectional drawing of SEG AUTO_{ADAPT} pumps, 2.6, 3.1 and 4.0 kW

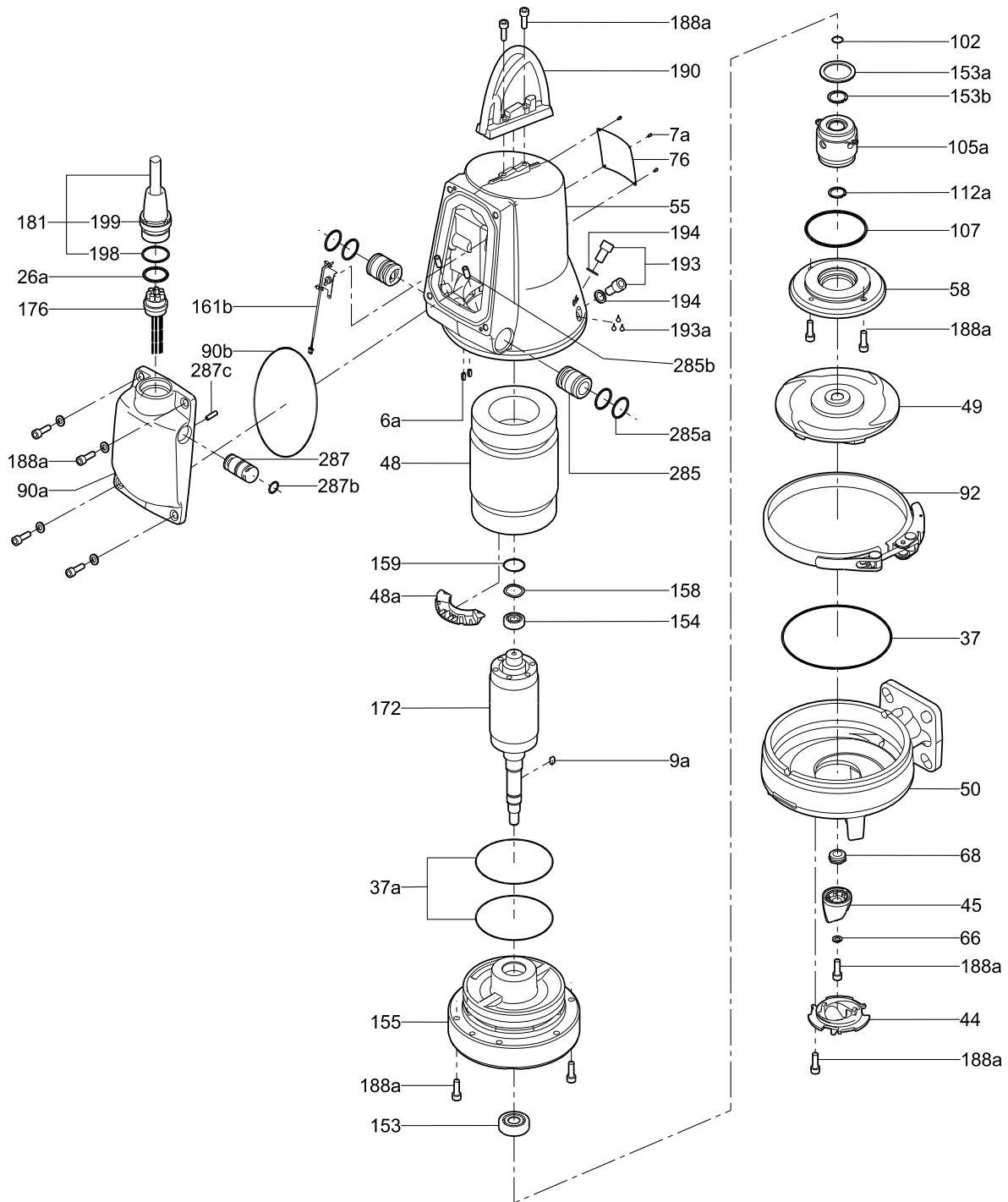

Fig. 12 Exploded view of SEG AUTO_{ADAPT} pumps, 2.6, 3.1 and 4.0 kW

TM04 5062 2109

Features

Ball bearings

The ball bearings are greased for life.

Top bearings:

- Up to and including 1.5 kW:
Single-row ball bearing 6201.
- 2.6 kW and up:
Single-row ball bearing 6205.

Bottom bearings:

- Up to and including 1.5 kW:
Single-row ball bearing 6303.
- 2.6 kW and up:
Angular-contact ball bearing 3205.

Shaft seal

The SEG range is available with two shaft seal variants. Both variants are fitted as cartridge seal units. The shaft seal separates the motor from the pumped liquid.

Pumps up to and including 1.5 kW have a silicon carbide/silicon carbide (SiC/SiC) mechanical shaft seal as primary seal and a lip seal as secondary seal. In connection with service, the mechanical shaft seal and the lip seal are supplied as one unit ready for fitting.

Pumps of 2.6 kW and up have a double seal consisting of a SiC/SiC mechanical shaft seal as primary seal and a carbon/aluminium oxide mechanical shaft seal as secondary seal.

Motor

The motor is a watertight, totally encapsulated motor.

Insulation class: F (155 °C).

Temperature class: F (105 °C).

Enclosure class: IP68.

For motor protection and sensors, see section *Sensors*.

Power supply cables

Standard cable

Cable type	Outer cable diameter [mm]	Bending radius	
		Fixed	Free
Lyniflex 4 G 1.5 mm ² + 3 x 1 mm ²	15.5 ± 0.5	60	90
Lyniflex 4 G 2.5 mm ² + 3 x 1 mm ²	17.0 ± 0.5	66	99
Lyniflex 7 G 2.5 mm ² + 3 x 1 mm ²	18.5 ± 0.5	74	111

EMC cable

Cable type	Outer cable diameter [mm]	Bending radius	
		Fixed	Free
3G3GC3G-F3x1AiC+4 G 2.5 mm ²	17.5 ± 0.5	85	170

As standard, the cables are 10 metres long. Other cable lengths are available on request. See section *List of variants*, page 12.

The number and dimension of cables depend on the motor size.

Cable entry

The stainless-steel plug is fastened with a union nut. The nut and O-rings provide sealing against ingress of the liquid.

The plug is filled with a special material that is cast into the plug around the leads of the cable. This prevents the ingress of water into the motor through the cable in case of cable breakage or adverse handling in connection with installation or service.

Sensors

SEG

As standard, the pump has two thermal switches incorporated in the motor windings to protect the motor against overheating.

SEG AUTO_{ADAPT}

As standard, the pump incorporates the following:

- One analog absolute-pressure transmitter.
- One dry-running sensor.
Explosion-proof versions have two dry-running sensors.
The dry-running sensor(s) are used for indicating the stop level in the first pump cycle and to prevent dry running.
On standard versions, the dry-running sensor can be overruled by an optional CIU unit if there is a risk of a floating layer.
- All pumps have two sets of thermal switches incorporated in the stator windings to protect the motor against overheating.
- Two Pt1000 sensors for analog measurement.
- Built-in motor protection I² (t) as extra safety.

Operating conditions

The pumps are designed for intermittent operation (S3). When completely submerged, the pumps can also operate continuously (S1).

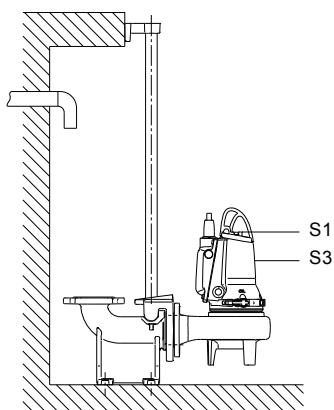

TM04 4810 2109

Fig. 13 Operation levels

- S3, intermittent operation:**
 The S3 operating mode means that within 10 minutes the pump must run for 4 minutes and be stopped for 6 minutes. See fig. 14. In this operating mode, the pump is partly submerged in the pumped liquid, i.e. the liquid level reaches at minimum the middle of the motor. See fig. 13.

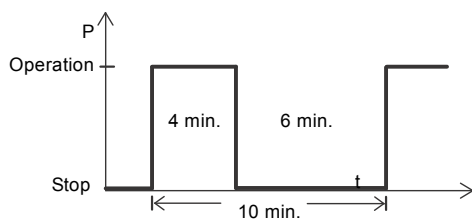

TM04 4527 1509

Fig. 14 S3 operation

- S1, continuous operation:**
 In this operating mode, the pump can operate continuously without having to be stopped for cooling. See fig. 15. Being completely submerged, the pump is sufficiently cooled by the surrounding liquid. See fig. 13.

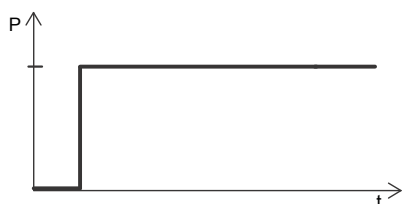

TM04 5228 1509

Fig. 15 S1 operation

Pumped liquids

pH value: 4 to 10.

Liquid temperature: 0 °C to +40 °C.

When pumping liquids with a density and/or a kinematic viscosity higher than that of water, use motors with correspondingly higher outputs.

For short periods (max. 3 minutes), temperatures up to 60 °C are permissible (non-Ex versions only).

Sound pressure level

The sound pressure level of the pump is lower than the limiting values stated in the EC Machinery Directive (2006/42/EC).

Motor range

Output power [kW]	Number of poles
0.9	2
1.2	2
1.5	2
2.6	2
3.1	2
4.0	2

Frequency converter operation

This section applies to SEG pumps only.

Note: The SEG AUTO_{ADAPT} pumps must not be used with a frequency converter.

In principle, all three-phase pumps, except the AUTO_{ADAPT} versions, can be connected to a frequency converter.

However, frequency converter operation will often expose the motor insulation system to a heavier load and cause the motor to be more noisy than usual due to eddy currents caused by voltage peaks.

In addition, large motors driven via a frequency converter will be loaded by bearing currents.

For more information, see the installation and operating instructions for the relevant frequency converter on www.grundfos.com (WebCAPS).

Approvals

SEG standard and SEG AUTO_{ADAPT} pumps have been tested by VDE.

The explosion-proof versions have been approved by KEMA according to the ATEX directive.

Approval standards

The standard versions are approved by LGA (notified body under the Construction Products Directive) according to EN 12050-1 and EN 12050-2.

Ex approval

The explosion protection classification of the pump is Europe CE 0344  II 2 G Ex b c d IIB T4 Gb.

Directive/standard	Code	Description
ATEX	CE 0344	= CE mark of conformity according to the ATEX directive 94/9/EC, Annex X. 0344 is the number of the notified body which has certified the quality system for ATEX.
		= Explosion protection mark.
	II	= Equipment group according to the ATEX directive, Annex II, point 2.2, defining the requirements applicable to the equipment in this group.
	2	= Equipment category according to the ATEX directive, Annex II, point 2.2, defining the requirements applicable to the equipment in this category.
	G	= Explosive atmospheres caused by gases, vapours or mists.
Harmonised European standard	Ex	= The equipment conforms to the harmonised European standard.
	b	Control of ignition sources according to EN 13463-6: 2005.
	c	Constructional safety according to EN 13463-5: 2003 and EN 13463-1: 2009.
	d	= Flame-proof enclosure according to EN 60079-1: 2007.
	II	= Suitable for use in explosive atmospheres (not mines).
	B	= Classification of gases according to EN 60079-0: 2006, Annex A. Gas group B includes gas group A.
	T4	= Maximum surface temperature is 135 °C according to EN 60079-0: 2006.
	Gb	Equipment protection level (IEC).
	X	= The equipment is subject to special conditions for safe use. The conditions are mentioned in the certificate and these installation and operating instructions.

IEC countries (Australia and others) Ex d IIB T4 Gb

Directive/standard	Code	Description
IEC 60079-0 and IEC 60079-1	Ex	= The equipment conforms to the harmonised European standard.
	d	= Flame-proof enclosure according to IEC 60079-1: 2007.
	II	= Suitable for use in explosive atmospheres (not mines).
	B	= Classification of gases according to IEC 60079-0: 2006, Annex A. Gas group B includes gas group A.
	T4	= Maximum surface temperature is 135 °C according to IEC 60079-0: 2006.
	IP68	= Enclosure class according to IEC 60529.
	X	The equipment is subject to special conditions for safe use. The conditions are mentioned in the certificate and the installation and operating instructions.

Wiring diagrams

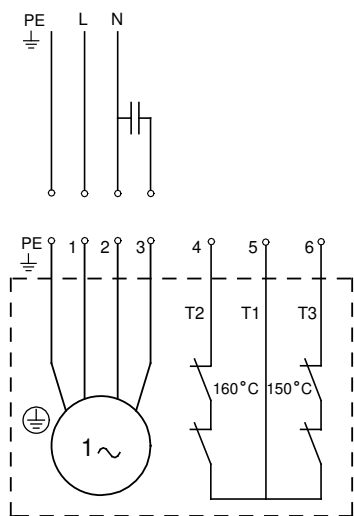

TM02 5587 4302

Fig. 16 Wiring diagram for single-phase SEG pumps

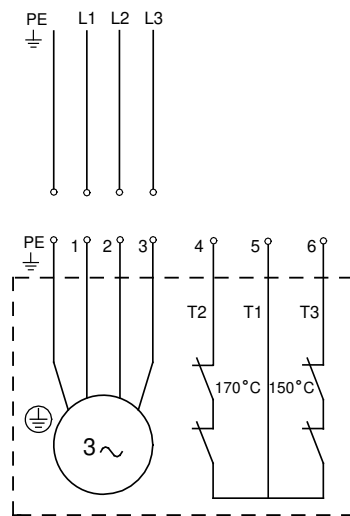

TM02 5587 4302

Fig. 18 Wiring diagram for three-phase SEG pumps

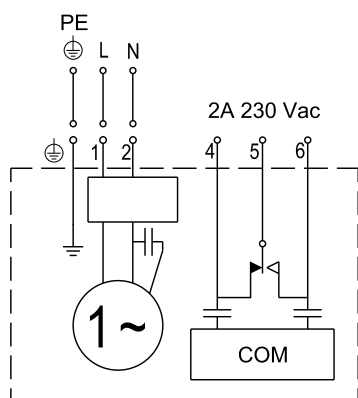

TM02 8396 5103

Fig. 17 Wiring diagram for single-phase SEG AUTO_{ADAPT} pumps

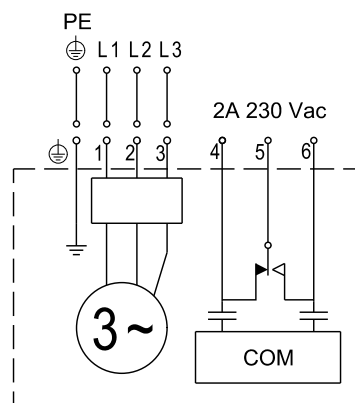

TM04 4298 1209

Fig. 19 Wiring diagram for three-phase SEG AUTO_{ADAPT} pumps

How to read the performance curves

The curves on the following pages apply to both SEG and SEG AUTO_{ADAPT} pumps as well as the explosion-proof versions.

SEG	Page
SEG.40.09.(E).(Ex).2.1.502	31
SEG.40.09.(E).(Ex).2.501/B/C	32
SEG.40.12.(E).(Ex).2.1.502	33
SEG.40.12.(E).(Ex).2.501/B/C	34
SEG.40.15.(E).Ex.2.501/B/C	35
SEG.40.26.(E).(Ex).2.501/B/C	36
SEG.40.31.(E).(Ex).2.501/B/C	37
SEG.40.40.(E).(Ex).2.501/B/C	38

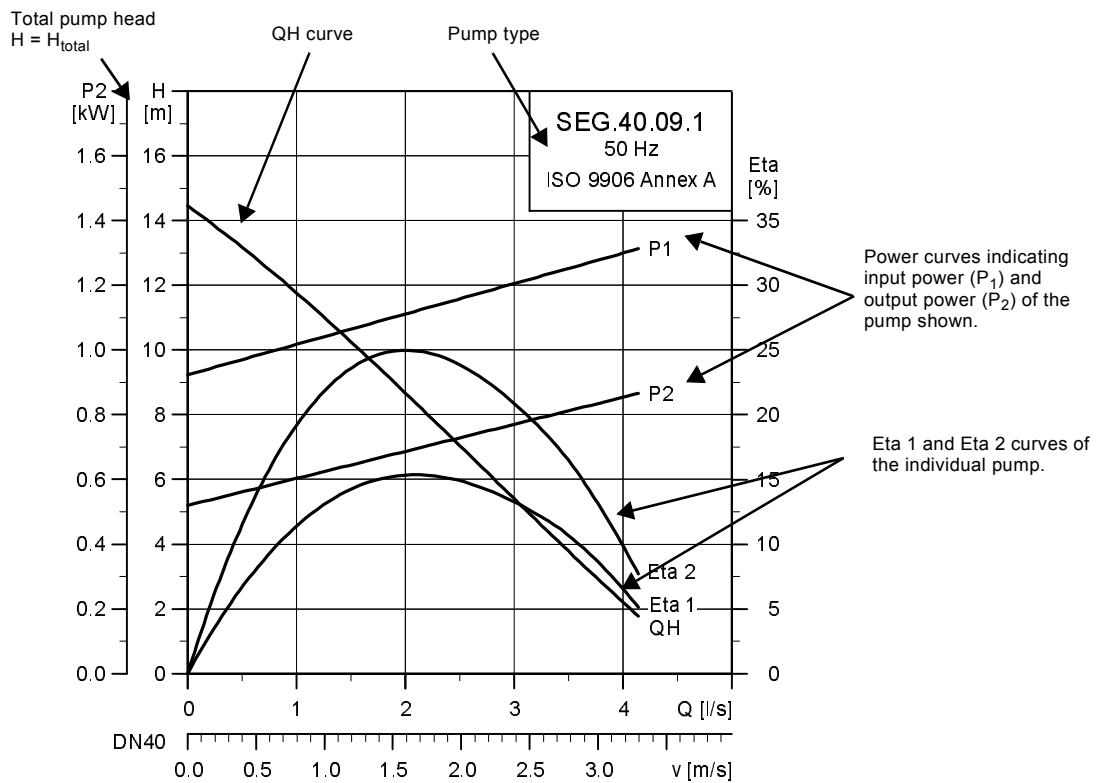

TM02 5270 2502

Curve conditions

The guidelines below apply to the curves on pages 31 to 38.

- Tolerances according to ISO 9906, Annex A.
- The curves show the pump performance with different impeller diameters at the rated speed.
- The curves apply to the pumping of airless water at a temperature of +20 °C and a kinematic viscosity of 1 mm²/s (1 cSt).
- The Eta curves show the efficiency of the pump for the different impeller diameters.
- The NPSH curves show average values measured under the same conditions as the performance curves.
When sizing the pump, add a safety margin of at least 0.5 m.
- In the case of other densities than 1000 kg/m³, the discharge pressure is proportional to the density.
- When pumping liquids with a density higher than 1000 kg/m³, motors with correspondingly higher outputs must be used.

Calculation of total head

The total pump head consists of the height difference between the measuring points + the differential head + the dynamic head.

$$H_{\text{total}} = H_{\text{geo}} + H_{\text{stat}} + H_{\text{dyn}}$$

H_{geo} : Height difference between measuring points.

H_{stat} : Differential head across the pump.

H_{dyn} : Calculated values based on the velocity of the pumped liquid on the suction and discharge sides of the pump.

Performance tests

The requested duty point of every pump is tested according to ISO 9906, Annex A, and without certification.

In the case of pumps ordered on the basis of impeller diameter only (no requested duty point), the pump will be tested at a duty point which is 2/3 of the maximum flow of the published performance curve which is related to the ordered impeller diameter (according to ISO 9906, Annex A).

If the customer requires either more points on the curve to be checked or certain minimum performances or certificates, individual measurements must be made, and a certificate can be ordered.

Certificates

Certificates have to be confirmed for every order and are available on request. See section *List of variants* on page 12.

Witness test

It is possible for the customer to witness the testing procedure according to ISO 9906.

The witness test is not a certificate and will not result in a written statement from Grundfos. The witness test itself is the only guarantee that everything is carried out as prescribed in the testing procedure.

If the customer wants to witness the test of the pump performance, this request must be stated on the order.

Performance curves/ Technical data

SEG and SEG AUTO_{ADAPT}

Performance curves, SEG.40.09.(E).(Ex).2.1.502

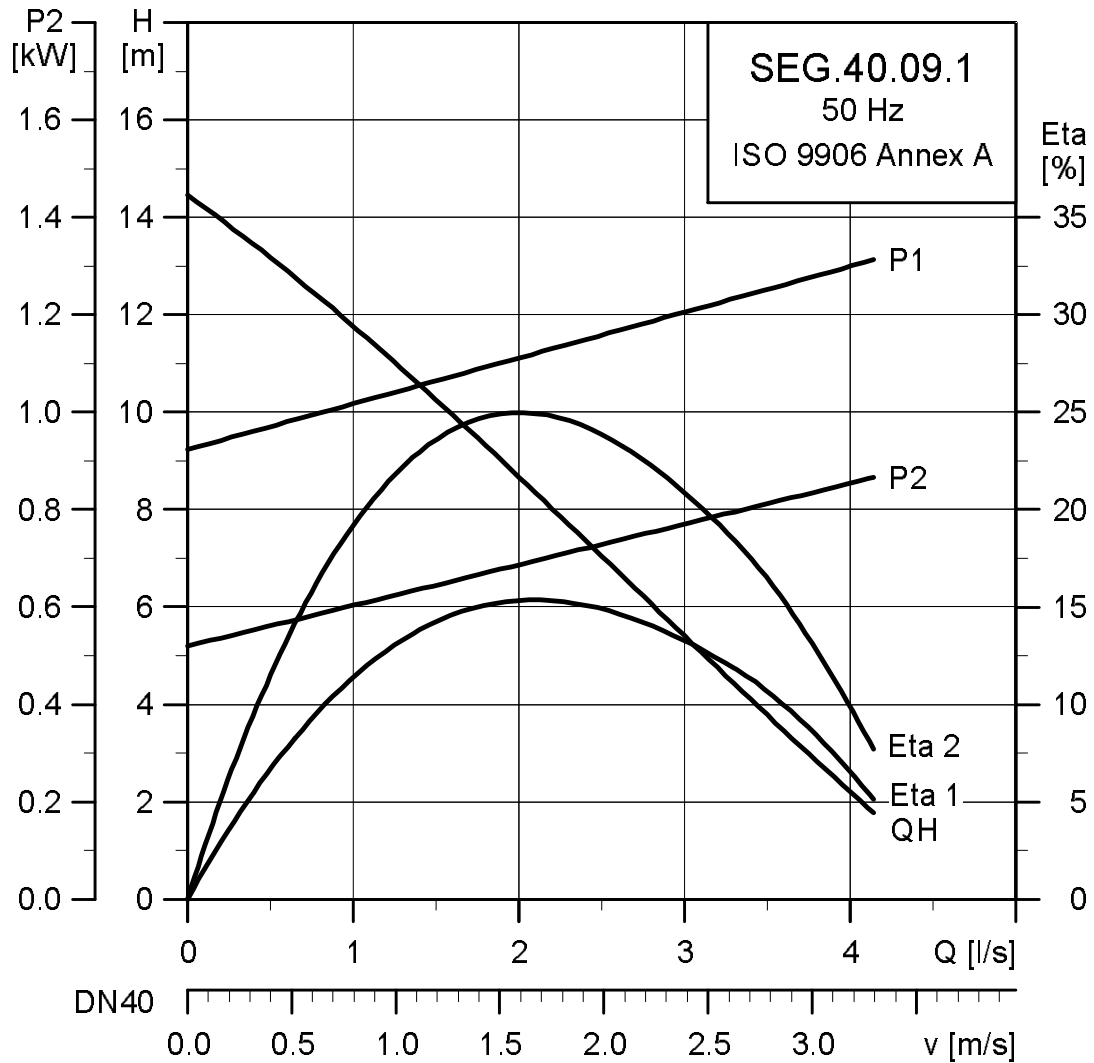

TM02.5270.1810

Electrical data

Voltage [V]	P1 [kW]	P2 [kW]	Number of poles	min ⁻¹	Starting method	I _N			I _{start}			η _{motor} [%]			Cos φ			Moment of inertia [kgm ²]	Breakdown torque M _{max.} [Nm]
						[A]	[A]	[A]	1/2	3/4	1/1	1/2	3/4	1/1	1/2	3/4	1/1		
1 x 230	1.4	0.9	2	2890	DOL	5.8	38	58	67	71	0.94	0.98	0.99	0.0036	7				

Pump data

Impeller type	Max. solids size	Max. number of starts per hour	Max. installation depth	Enclosure class	Insulation class	Max. liquid temperature	pH	Ex class
	[mm]							
Semi-open	Grinder system	20	10	IP68	F	40	4-10	EEX d IIB T4 Class I Zone II

Performance curves, SEG.40.09.(E).(Ex).2.50B/C

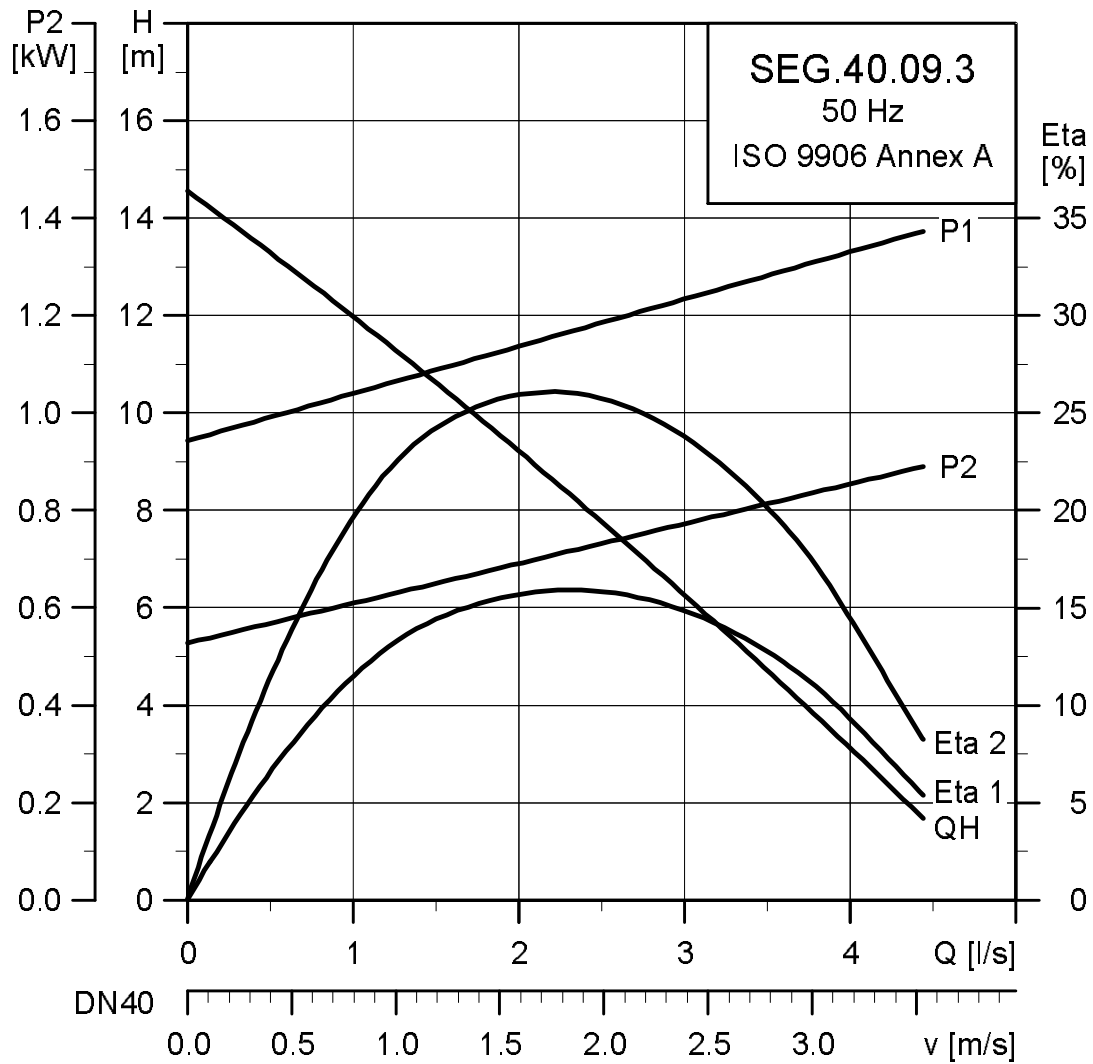

TM02.5269.1810

Electrical data

Voltage [V]	P1 [kW]	P2 [kW]	Number of poles	min ⁻¹	Starting method	I _N			I _{start}			η _{motor} [%]			Cos φ			Moment of inertia [kgm ²]	Breakdown torque M _{max.} [Nm]
						[A]	[A]	[A]	1/2	3/4	1/1	1/2	3/4	1/1	1/2	3/4	1/1		
1 x 230-240	1.4	0.9	2	2860	DOL	4.5	36	60	67	71	0.5	0.62	0.72	0.0036	12				
3 x 400-415	1.4	0.9	2	2860	DOL	2.6	21	60	67	71	0.5	0.62	0.72	0.0036	12				

Pump data

Impeller type	Max. solids size	Max. number of starts per hour	Max. installation depth	Enclosure class	Insulation class	Max. liquid temperature	pH	Ex class
	[mm]					[°C]		
Semi-open	Grinder system	20	10	IP68	F	40	4-10	EEX d IIB T4 Class I Zone II

Performance curves/ Technical data

SEG and SEG AUTO_{ADAPT}

Performance curves, SEG.40.12.(E).(Ex).2.1.502

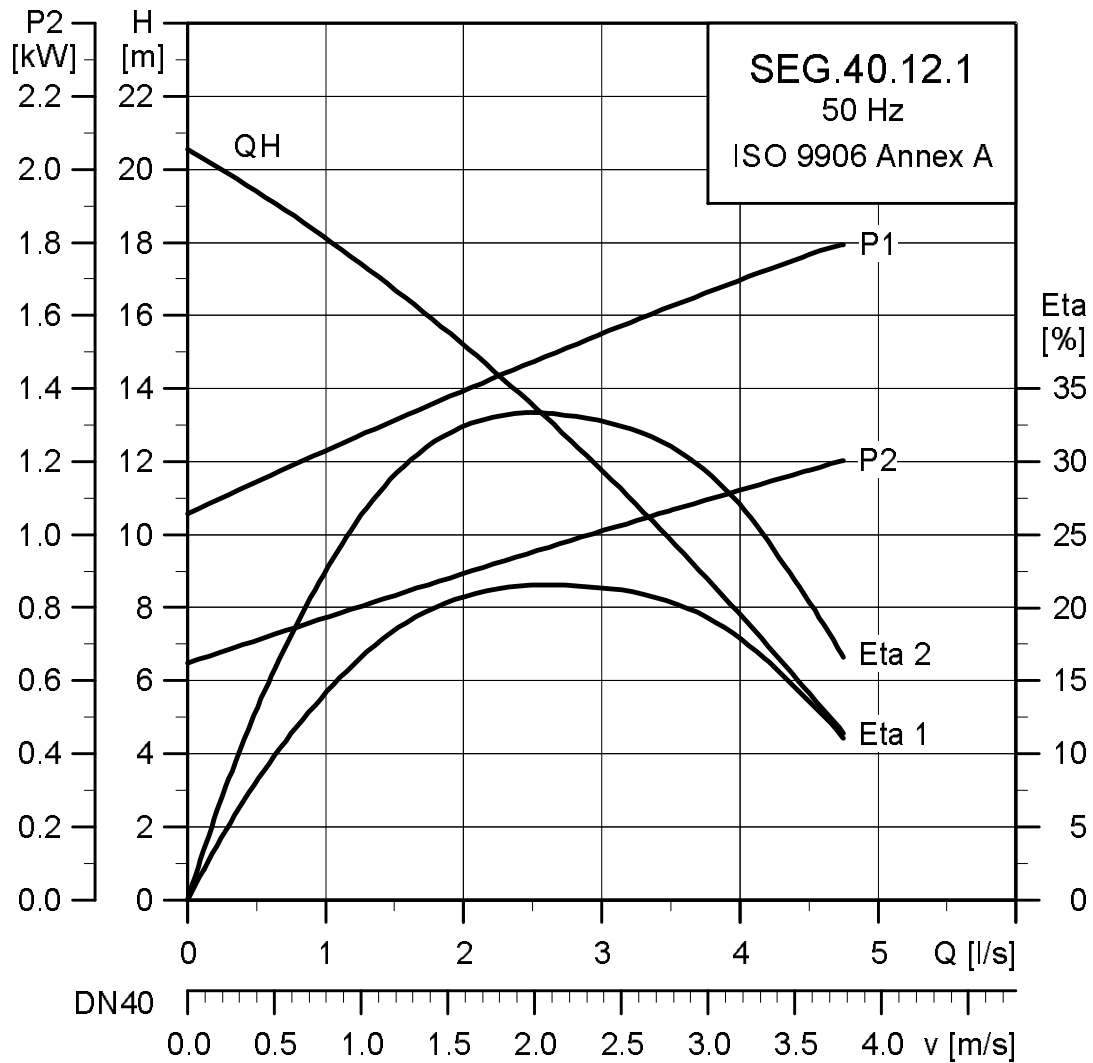

TM02-5268-2502

Electrical data

Voltage [V]	P1 [kW]	P2 [kW]	Number of poles	min ⁻¹	Starting method	I _N			I _{start}			η _{motor} [%]			Cos φ			Moment of inertia [kgm ²]	Breakdown torque M _{max.} [Nm]
						[A]	[A]	[A]	1/2	3/4	1/1	1/2	3/4	1/1	1/2	3/4	1/1		
1 x 230	1.8	1.2	2	2820	DOL	8.2	38	65	71	73	0.97	0.99	0.99	0.0038	7				

Pump data

Impeller type	Max. solids size	Max. number of starts per hour	Max. installation depth	Enclosure class	Insulation class	Max. liquid temperature	pH	Ex class
	[mm]							
Semi-open	Grinder system	30	10	IP68	F	40	4-10	EEX d IIB T4 Class I Zone II

Performance curves, SEG.40.12.(E).(Ex).2.50B/C

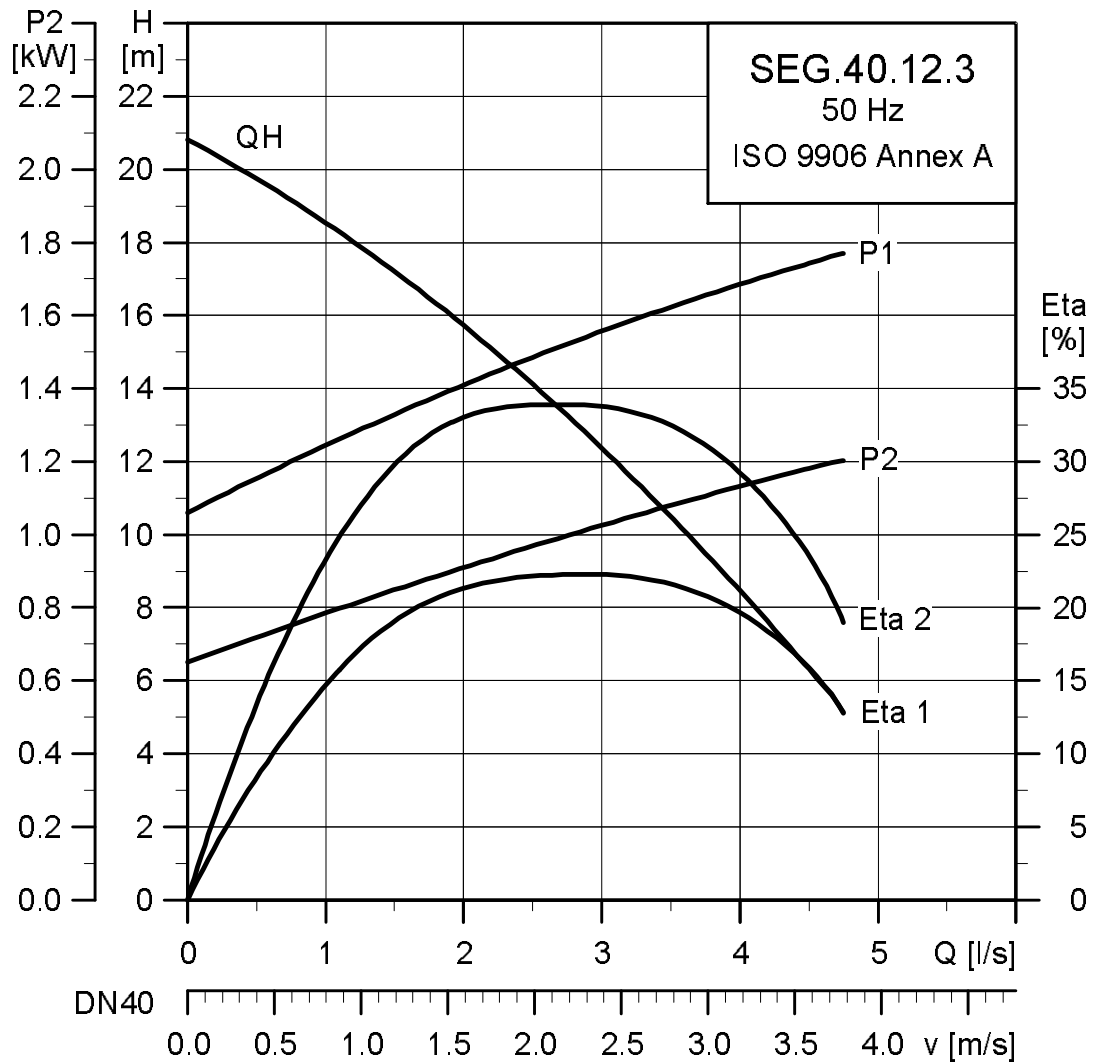

TM02.5267.1810

Electrical data

Voltage [V]	P1 [kW]	P2 [kW]	Number of poles	min ⁻¹	Starting method	I _N			I _{start}			η _{motor} [%]			Cos φ			Moment of inertia [kgm ²]	Breakdown torque M _{max.} [Nm]
						[A]	[A]	[A]	1/2	3/4	1/1	1/2	3/4	1/1	1/2	3/4	1/1		
3 x 230-240	1.8	1.2	2	2750	DOL	5.4	36	66	71	73	0.58	0.73	0.81	0.0038	12				
3 x 400-415	1.8	1.2	2	2750	DOL	3.1	21	66	71	73	0.58	0.73	0.81	0.0038	12				

Pump data

Impeller type	Max. solids size	Max. number of starts per hour	Max. installation depth	Enclosure class	Insulation class	Max. liquid temperature	pH	Ex class
	[mm]							
Semi-open	Grinder system	30	10	IP68	F	40	4-10	EEX d IIB T4 Class I Zone II

Performance curves/ Technical data

SEG and SEG AUTO_{ADAPT}

Performance curves, SEG.40.15.(E).(Ex).2.50B/C

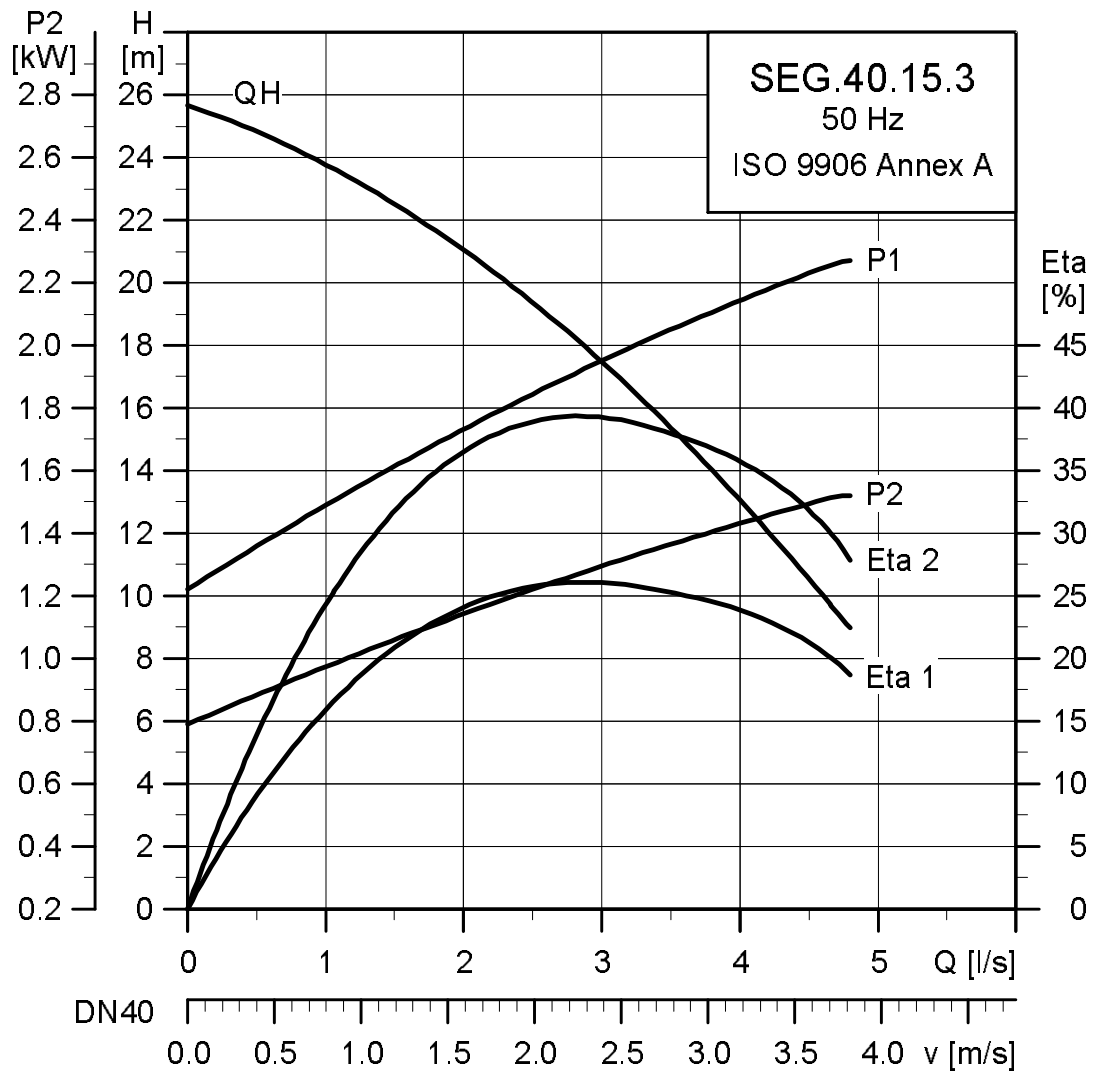

TM02.5266 1810

Electrical data

Voltage [V]	P1 [kW]	P2 [kW]	Number of poles	min ⁻¹	Starting method	I _N			η _{motor} [%]			Cos φ			Moment of inertia [kgm ²]	Breakdown torque M _{max.} [Nm]
						[A]	[A]		1/2	3/4	1/1	1/2	3/4	1/1		
3 x 230-240	2.3	1.5	2	2700	DOL	6.6	36		69	71	72	0.66	0.79	0.87	0.004	12
3 x 400-415	2.3	1.5	2	2750	DOL	3.8	21		69	73	72	0.66	0.79	0.87	0.004	12

Pump data

Impeller type	Max. solids size	Max. number of starts per hour	Max. installation depth	Enclosure class	Insulation class	Max. liquid temperature	pH	Ex class
	[mm]							
Semi-open	Grinder system	30	10	IP68	F	40	4-10	EEX d IIB T4 Class I Zone II

Performance curves/ Technical data

SEG and SEG AUTO_{ADAPT}

Performance curves, SEG.40.26.(E).(Ex).2.50B/C

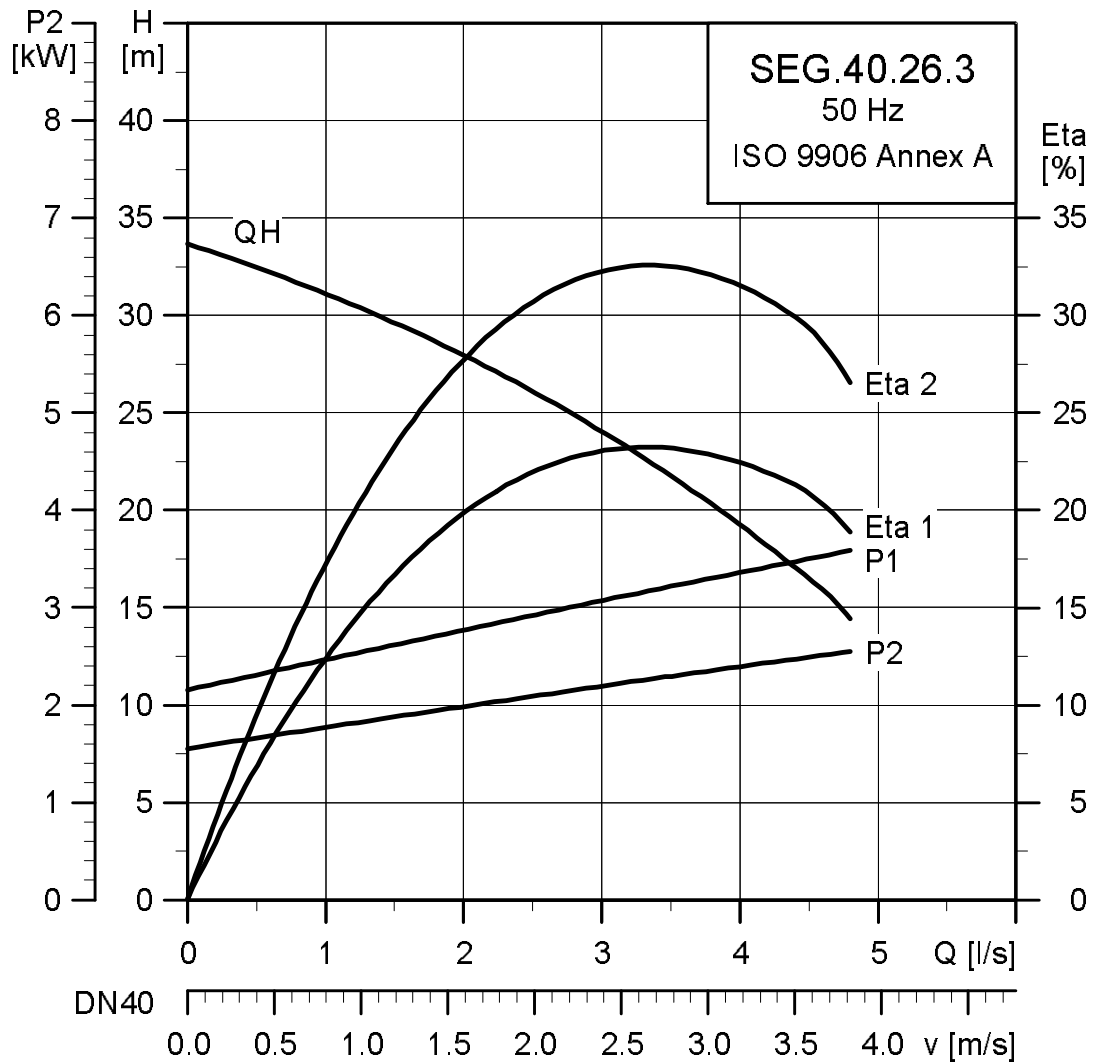

TM02.5271.1810

Electrical data

Voltage [V]	P1 [kW]	P2 [kW]	Number of poles	min ⁻¹	Starting method	I _N			I _{start}			η _{motor} [%]			Cos φ			Moment of inertia [kgm ²]	Breakdown torque M _{max.} [Nm]
						[A]	[A]	[A]	1/2	3/4	1/1	1/2	3/4	1/1	1/2	3/4	1/1		
3 x 230-240	3.7	2.6	2	2870	DOL	10.6	57	84	84	82	0.68	0.81	0.87	0.0093	24				
3 x 400-415	3.7	2.6	2	2870	DOL	6.1	33	84	84	82	0.68	0.81	0.87	0.0093	24				

Pump data

Impeller type	Max. solids size	Max. number of starts per hour	Max. installation depth	Enclosure class	Insulation class	Max. liquid temperature	pH	Ex class
	[mm]							
Semi-open	Grinder system	30	10	IP68	F	40	4-10	EEX d IIB T4 Class I Zone II

Performance curves/ Technical data

SEG and SEG AUTO_{ADAPT}

Performance curves, SEG.40.31.(E).(Ex).2.50B/C

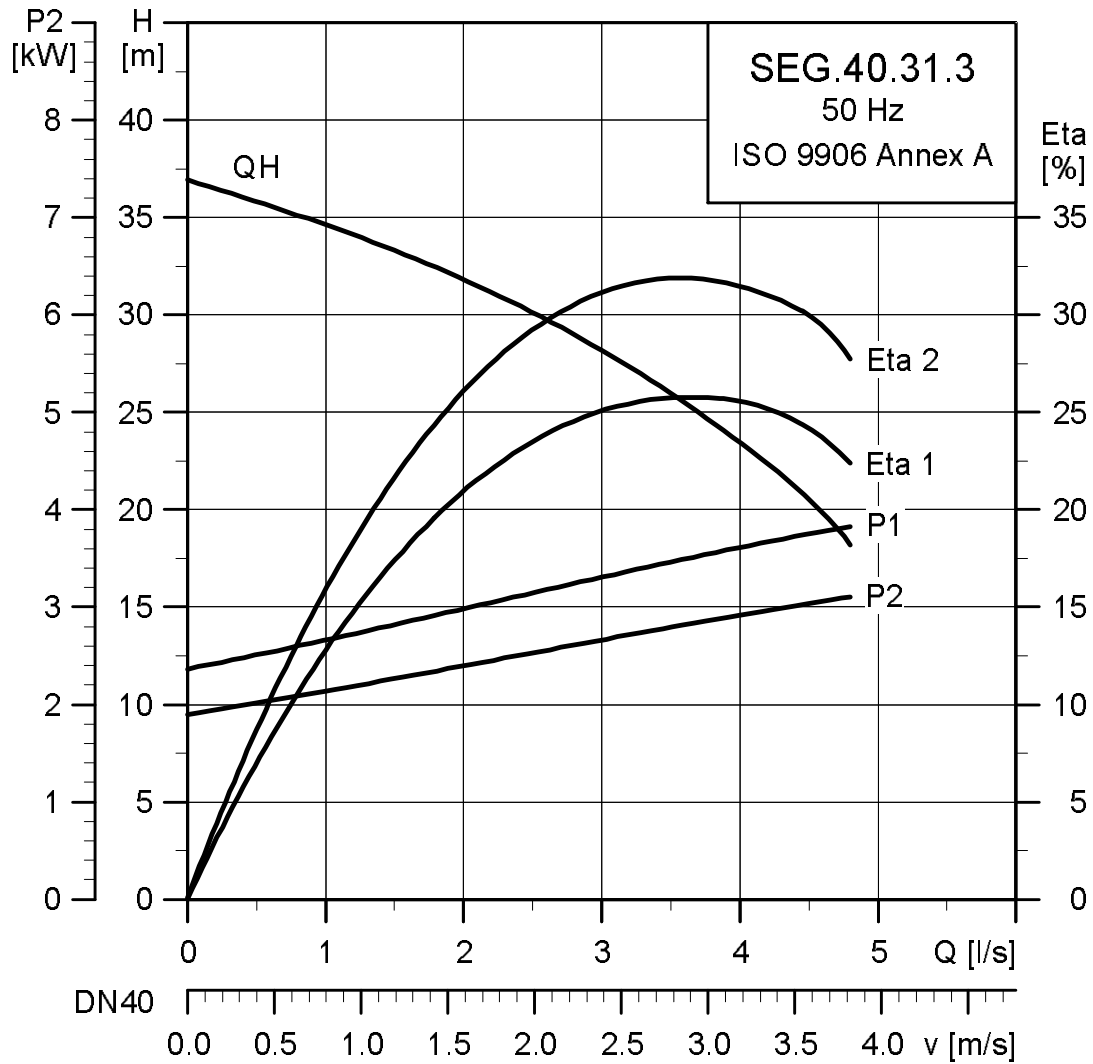

TM02.5272.1810

Electrical data

Voltage [V]	P1 [kW]	P2 [kW]	Number of poles	min ⁻¹	Starting method	I _N		η _{motor} [%]			Cos φ			Moment of inertia [kgm ²]	Breakdown torque M _{max.} [Nm]
						[A]	[A]	1/2	3/4	1/1	1/2	3/4	1/1		
3 x 230-240	3.9	3.1	2	2900	DOL	10.9	74	79	82	84	0.71	0.81	0.86	0.01	33
3 x 400-415	3.9	3.1	2	2900	DOL	6.3	43	79	82	84	0.71	0.81	0.86	0.01	33

Pump data

Impeller type	Max. solids size	Max. number of starts per hour	Max. installation depth	Enclosure class	Insulation class	Max. liquid temperature	pH	Ex class
	[mm]							
Semi-open	Grinder system	30	10	IP68	F	40	4-10	EEX d IIB T4 Class I Zone II

Performance curves/ Technical data

SEG and SEG AUTO_{ADAPT}

Performance curves, SEG.40.40.(E).(Ex).2.50B/C

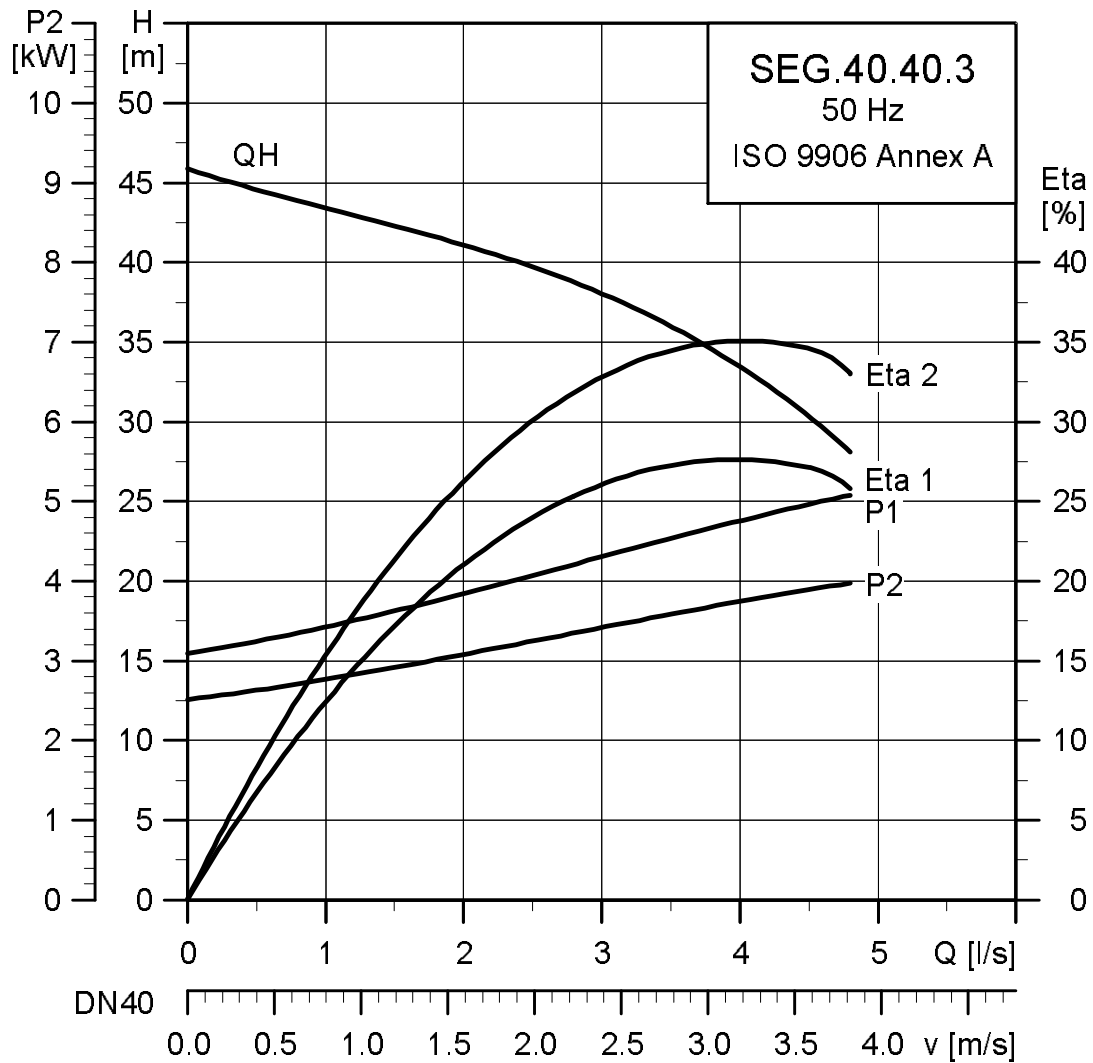

TM02.5273.1810

Electrical data

Voltage [V]	P1 [kW]	P2 [kW]	Number of poles	min ⁻¹	Starting method	I _N		η _{motor} [%]			Cos φ			Moment of inertia [kgm ²]	Breakdown torque M _{max.} [Nm]
						[A]	[A]	1/2	3/4	1/1	1/2	3/4	1/1		
3 x 230-240	5.2	4.0	2	2830	DOL	14.2	74	80	82	82	0.81	0.89	0.92	0.011	33
3 x 400-415	5.2	4.0	2	2830	DOL	8.2	43	80	82	82	0.81	0.89	0.92	0.011	33

Pump data

Impeller type	Max. solids size	Max. number of starts per hour	Max. installation depth	Enclosure class	Insulation class	Max. liquid temperature	pH	Ex class
	[mm]					[°C]		
Semi-open	Grinder system	30	10	IP68	F	40	4-10	EEX d IIB T4 Class I Zone II

SEG pumps

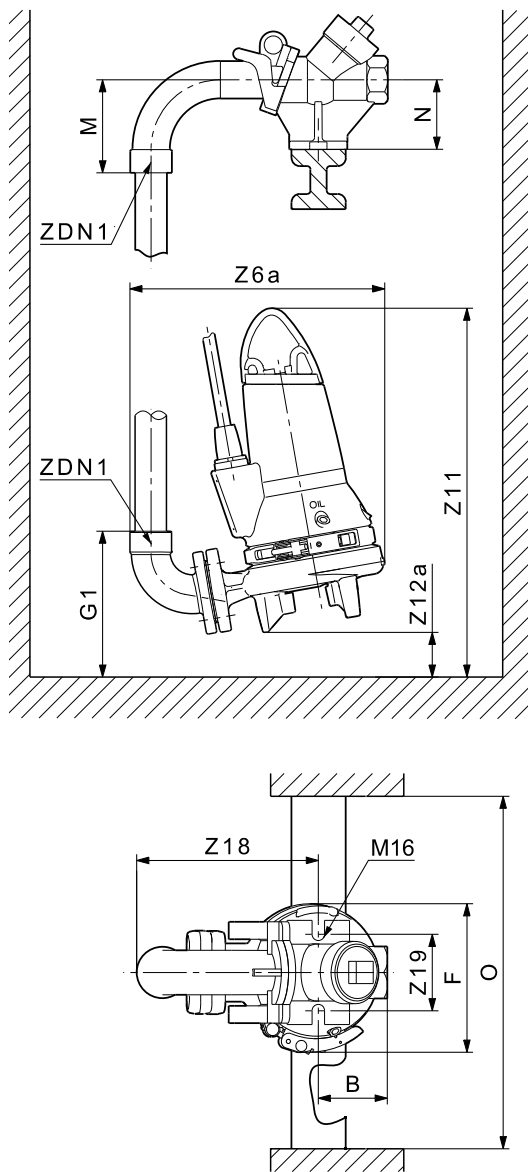

Fig. 20 Installation on hookup auto-coupling

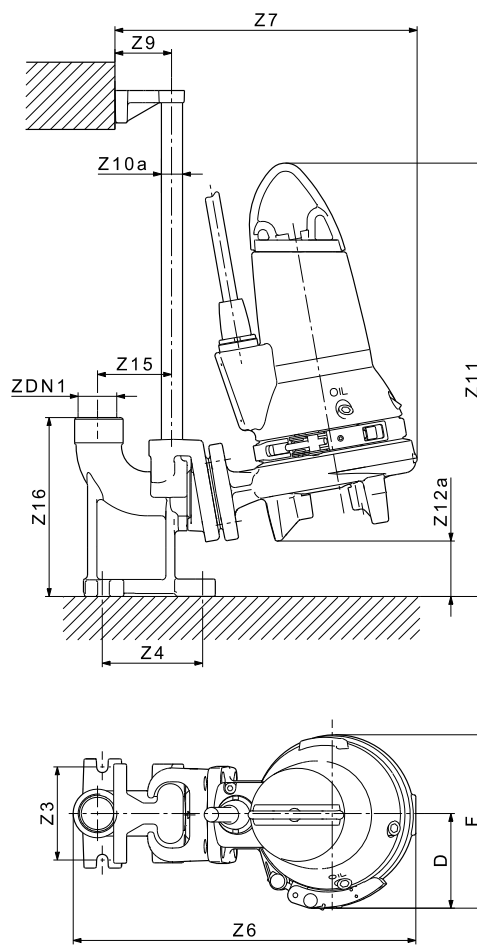

Fig. 21 Installation on auto-coupling

Power [kW]	A	B	C	D	DN2	E	F	G1	H	I	M	N	O	V1	Y2	Z3	Z4	Z6	Z6a	Z7	Z9
0.9, 1.2 and 1.5	456	100	255	99	DN 40	154	216	214	71	123	134	100		500	116	115	118	424	365	374	70
2.6	527	100	292	119	DN 40	173	256	215	60	143	134	100	min. 600	582	115	115	118	460	365	410	70
3.1 and 4.0	567	100	292	119	DN 40	173	256	214	60	144	134	100		622	115	115	118	460	365	410	70

Power [kW]	Z10a	Z11	Z12a	Z15	Z16	Z18	Z19	ZDN1
0.9, 1.2 and 1.5	3/4" - 1"	536	68	90	221	271	120	Rp 1 1/2
2.6	-	619	80	90	221	271	120	Rp 1 1/2
3.1 and 4.0	-	657	79	90	221	271	120	Rp 1 1/2

SEG AUTO_{ADAPT} pumps

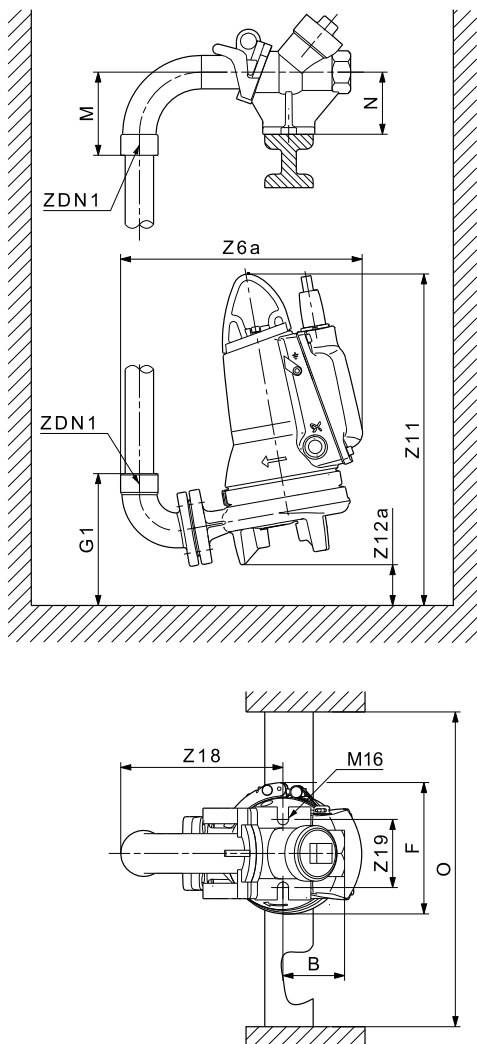

Fig. 22 Installation on hookup auto-coupling

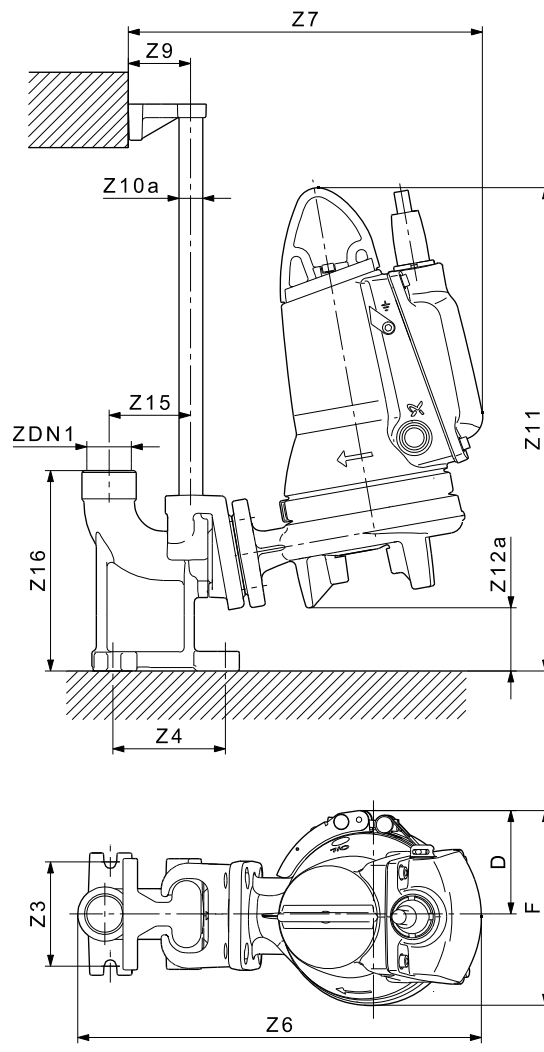

Fig. 23 Installation on auto-coupling

TM04 5648 1310

TM04 4483 1310

Power [kW]	A	B	C	D	DN2	E	F	G1	H	I	M	N	O	V1	Y2	Z3	Z4	Z6	Z6a	Z7	Z9	
0.9, 1.2 and 1.5	456	100	255	99	DN 40	154	216	214	71	140	134	100		500	116	115	118	495	388	397	216	
2.6	527	100	292	119	DN 40	173	256	215	60	166	134	100		min. 600	582	115	115	118	531	423	433	256
3.1 and 4.0	567	100	292	119	DN 40	173	256	214	60	166	134	100		622	115	115	118	531	423	433	256	

Power [kW]	Z10a	Z11	Z12a	Z15	Z16	Z18	Z19	ZDN1
0.9, 1.2 and 1.5	3/4" - 1"	536	68	90	221	271	120	Rp 1 1/2
2.6	-	619	80	90	221	271	120	Rp 1 1/2
3.1 and 4.0	-	657	79	90	221	271	120	Rp 1 1/2

SEG pumps

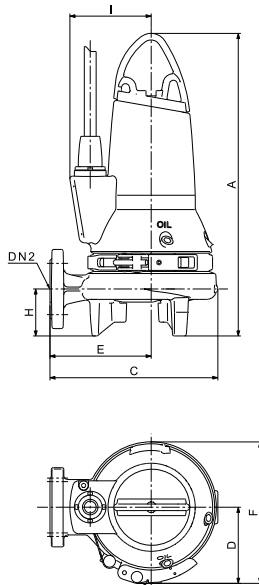

TM02 5387 1310

Fig. 24 Free-standing installation

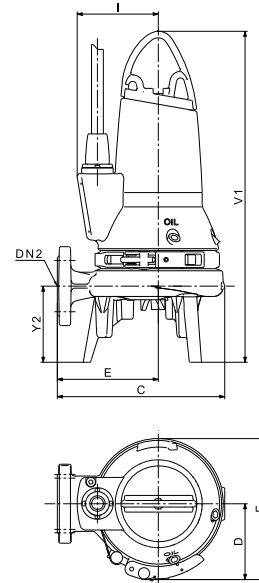

TM02 5974 1310

Fig. 25 Free-standing installation with foot extensions

Power [kW]	A	B	C	D	DN2	E	F	G1	H	I	M	N	O	V1	Y2	Z3	Z4	Z6	Z6a	Z7	Z9
0.9, 1.2 and 1.5	456	100	255	99	DN 40	154	216	214	71	123	134	100		500	116	115	118	424	365	374	70
2.6	527	100	292	119	DN 40	173	256	215	60	143	134	100	min. 600	582	115	115	118	460	365	410	70
3.1 and 4.0	567	100	292	119	DN 40	173	256	214	60	144	134	100		622	115	115	118	460	365	410	70

Power [kW]	Z10a	Z11	Z12a	Z15	Z16	Z18	Z19	ZDN1
0.9, 1.2 and 1.5	3/4" - 1"	536	68	90	221	271	120	Rp 1 1/2
2.6	-	619	80	90	221	271	120	Rp 1 1/2
3.1 and 4.0	-	657	79	90	221	271	120	Rp 1 1/2

SEG AUTO_{ADAPT} pumps

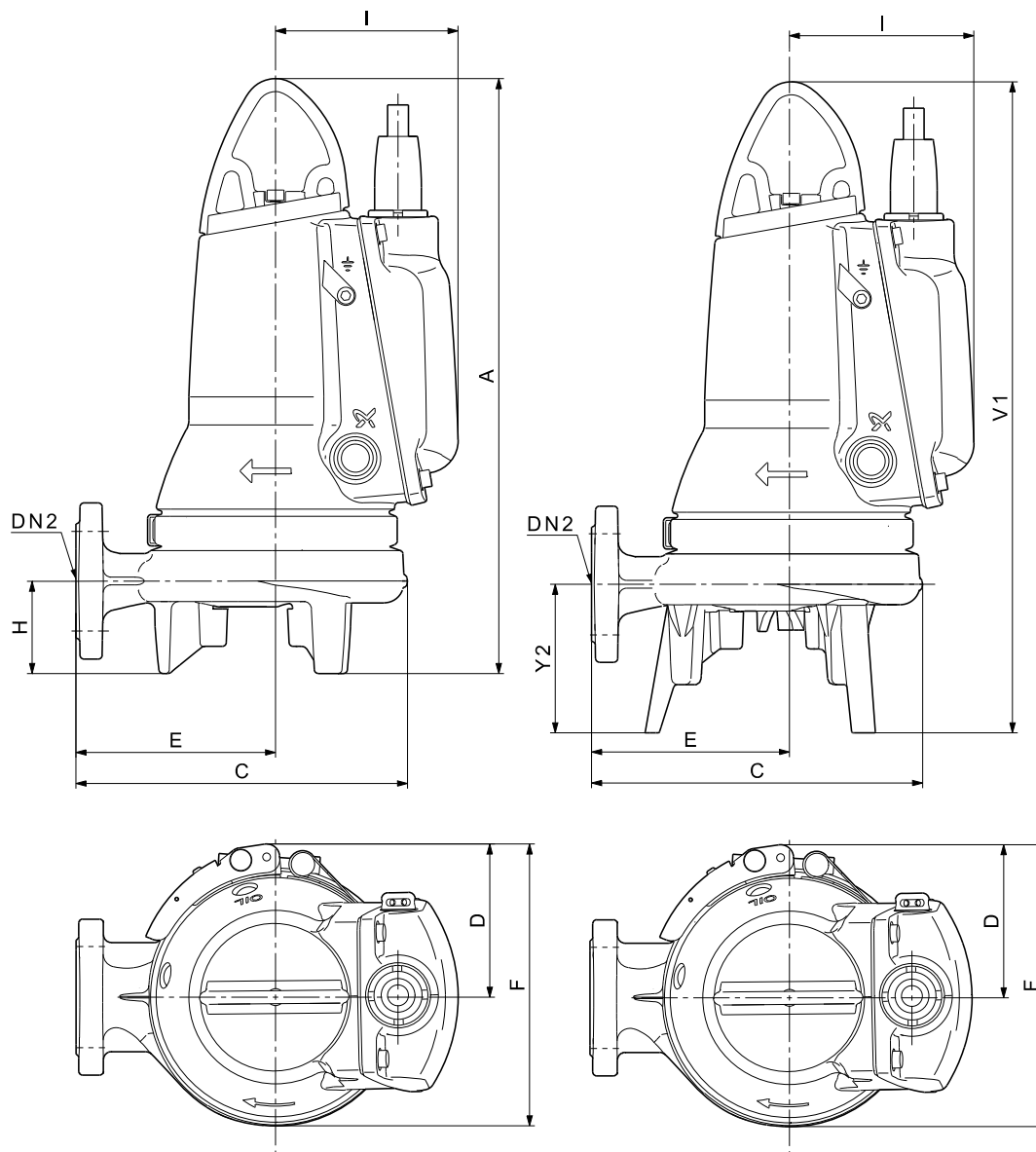





TMD4 4485 1310

Fig. 26 Free-standing installation with or without foot extensions

Power [kW]	A	B	C	D	DN2	E	F	G1	H	I	M	N	O	V1	Y2	Z3	Z4	Z6	Z6a	Z7	Z9
0.9, 1.2 and 1.5	456	100	255	99	DN 40	154	216	214	71	140	134	100		500	116	115	118	495	388	397	216
2.6	527	100	292	119	DN 40	173	256	215	60	166	134	100	min. 600	582	115	115	118	531	423	433	256
3.1 and 4.0	567	100	292	119	DN 40	173	256	214	60	166	134	100		622	115	115	118	531	423	433	256

Power [kW]	Z10a	Z11	Z12a	Z15	Z16	Z18	Z19	ZDN1
0.9, 1.2 and 1.5	3/4" - 1"	536	68	90	221	271	120	Rp 1 1/2
2.6	-	619	80	90	221	271	120	Rp 1 1/2
3.1 and 4.0	-	657	79	90	221	271	120	Rp 1 1/2

Installation systems for SEG and SEG AUTO_{ADAPT} pumps

No	Product	Description	Dimensions	Product number
1		TM01 7173 1409 Lifting chain with shackle. With certificates. Galvanised steel.	3 m	96497466
			6 m	96497465
			10 m	96497464
2		TM02 5980 4602 Auto-coupling system complete, i.e. upper guide rail holder, bolts, nuts, gaskets, guide claw and base stand. Cast iron.	DN 40 / Rp 1 1/2	96076063
3		TM02 5979 4602 Hookup auto-coupling, i.e. base stand, counterpart, bolts, nuts and gaskets. Cast iron.	DN 40 / Rp 1 1/2	96076089
			Rp / Rp 2	96004442
4		TM03 0716 0505 Three loose feet to be fitted to the pump housing of free-standing pumps.		96076196

Other accessories

5		TM04 7452 2010 Grundfos Powerline PC Tool Link USB communication unit .	All AUTO _{ADAPT} pumps	97655366
---	---	--	---------------------------------	----------

SEG pumps

Level controllers

Grundfos offers a wide range of pump controllers to keep a watchful eye on liquid levels in the wastewater collecting tank, ensuring correct operation and protection of the pumps.

Controller ranges:

- Dedicated Controls, DC and DCD control cabinets
- LC and LCD level controllers
- CU 100 control box.

The DC, LC and CU 100 are designed for one-pump installations, and the DCD and LCD are designed for two-pump installations.

Dedicated Controls

Grundfos Dedicated Controls is a control system that can control and monitor one or two Grundfos wastewater pumps and a mixer or a flush valve.

Dedicated Controls is used in installations requiring advanced control and data communication.

Main components of the Dedicated Controls system:

- CU 361 control unit
- IO 351B module (general I/O module).

Dedicated Controls is available either as separate components or as control cabinets, i.e. DC and DCD.

The control system can be operated by the following:

- float switches
- a level sensor
- a level sensor and safety float switches.

The control cabinet is available for the following pump sizes and starting methods:

- pumps up to and including 9 kW, direct-on-line starting
- pumps up to and including 30 kW, star-delta starting
- pumps up to and including 30 kW, soft starter.

The separate control unit and modules can be built for practically any size of system.



GrA6270

Fig. 27 Dedicated Controls control cabinet

The DC and DCD control cabinets can be fitted with various units:

- The CU 361 control unit, which is the 'brain' of the Dedicated Controls system, is fitted in the cabinet front. The CU 361 can be fitted with one of the Grundfos CIM communication modules mentioned below, depending on the monitoring needs or the SCADA system:
 - The CIM 200 is a communication module used for the Modbus RTU fieldbus protocol.
 - The CIM 250 is a communication module used for GSM/GPRS communication. The CIM 250 establishes communication between the CU 361 and a SCADA system, thereby allowing the application to be monitored and controlled remotely. This module also offers SMS messaging, for example status and alarm messages.
 - The CIM 270 is a communication module for the Grundfos Remote Management system (GRM). The CIM 270 establishes communication between the CU 361 and the GRM, thereby allowing the application to be monitored and controlled remotely.
- The IO 351B module, which is a general I/O module. The IO 351B communicates with the CU 361 via GENibus.
- The MP 204 motor protector (optional), which provides many electrical status values, for example voltage, current, power, insulation resistance and energy. The MP 204 offers better protection of the pumps than a conventional motor protection device.
- The CUE/VFD (optional), which is either a Grundfos variable-frequency converter or a general variable-frequency converter, also offers better pump protection and a more steady flow through the pit pipes, so the pumps are treated well and the energy consumption is kept at a minimum.

For further information, see the data booklet or installation and operating instructions for Dedicated Controls on www.Grundfos.com (WebCAPS).

LC and LCD

The Grundfos LC and LCD ranges of level controllers comprise three series with a total of six variants:

- LC and LCD 107 operated by air bells
- LC and LCD 108 operated by float switches
- LC and LCD 110 operated by electrodes.

All controllers are ideally suited for applications requiring up to 11 kW motors for direct-on-line starting. The LC and LCD can also be supplied with an integrated star-delta starter for applications requiring larger motors up to and including 30 kW.

Features and benefits

- Control of one pump (LC) or two pumps (LCD).
- Automatic alternating operation of two pumps (LCD).
- Automatic test run (prevents shaft seals from becoming jammed in the event of long periods of inactivity).
- Water hammer protection.
- Starting delay after power supply failure.
- Automatic alarm resetting, if required.
- Automatic restarting, if required.
- Alarm outputs as NO and NC.



TM04 2360 2408

Fig. 28 LCD 110 for two-pump installations

When an SMS module (optional) is fitted in an LC or LCD controller, it acts as a time recorder for the pumps, and when programmed (using an ordinary mobile phone with text messaging facility), it can send text messages containing "high-level alarm", "general alarm", information about operation and the number of times the pump has started. The SMS module is also available with battery and can thus send text messages that will inform you of power failure and when the power has been restored.

For further information, see the data booklet or installation and operating instructions for the LC and LCD controllers on www.Grundfos.com (WebCAPS).

CU 100

The CU 100 control box is designed for the starting, operation and protection of small wastewater pumps.

The control box is available in several variants which can be used for the following:

- single-phase pumps (up to and including 9 A)
 - three-phase pumps (up to and including 5 A)
- and
- start/stop by means of a float switch
 - manual start/stop.

During manual operation, the pump is started and stopped with the on/off switch.

During automatic operation, the float switch will start and stop the pump.

For further information, see the installation and operating instructions for the CU 100 on www.Grundfos.com (WebCAPS).



TM02 6459 0703

Fig. 29 CU 100

SEG AUTO_{ADAPT} pumps

Grundfos CIU unit

The Grundfos CIU unit (CIU = Communication Interface Unit) is used as a communication interface between a Grundfos product and a main network.

The CIU unit is used as an interface for following:

- Configuration of pump parameters required for water level control.
- Online monitoring of pit and pump values.
- Manual water level control (forced start/stop).
- Obtaining of measured and logged data that is valuable for pump service and pit optimisation.

The CIU unit is designed for use together with Grundfos SEG AUTO_{ADAPT} pumps. Communication can be established with the Grundfos R100 remote control or by using the main network interface of the CIU unit.

Available CIU units:

- CIU 902 unit (without CIM module)
- CIU 202 Modbus unit
- CIU 252 GSM/GPRS unit
- CIU 272 GRM unit (Grundfos Remote Management).

The CIU unit incorporates one or two modules:

- Multi-purpose IO module with I/O functionality, IR communication interface and powerline communication.
- CIM 2XX module (optional).

For further information about the CIM module fitted, see installation and operating instructions for the relevant CIM module.

If a CIM module is fitted in the CIU unit, the sensors connected to the digital input of the IO module can be remotely monitored from a centrally located SCADA system.

Grundfos R100 remote control

The Grundfos R100 remote control is designed for wireless IR communication with Grundfos products.

The R100 can communicate with the SEG AUTO_{ADAPT} pumps via a CIU unit.

The R100 is to be regarded as an ordinary service and measuring tool and is therefore designed to withstand wear and stress from everyday use.

Name	DC	DCD	LC	LCD	CU 100	AUTO _{ADAPT}	CIU
Application							
One pump	•	•	•	•	•	•	•
Two pumps		•		•		•	•
Mixer	•	•					
Battery back-up	•	•					
Level sensor							
Float switches	•	•	•	•	•		• ⁷⁾
Electrodes			•	•			• ⁷⁾
Air bells			•	•			• ⁷⁾
Pressure sensor	•	•				• ³⁾	• ⁷⁾
Ultrasonic sensor	•	•					• ⁷⁾
Analog level sensor with safety float switches	•	•					• ⁷⁾
Starting method							
Direct-on-line starting (DOL)	•	•	•	•	•	•	•
Star-delta starting	•	•	•	•			
Soft starter	•	•					
Basic functions							
Start and stop of pump(s)	•	•	•	•	•	•	•
Pump alternation		•		•		•	•
High-level alarm	•	•	•	•		•	•
Dry-running level alarm	•	•	•	•		•	•
Flow measurement (calculated or via flow sensor)	•	•					
Pump statistics	•	•				• ⁴⁾	•
Conflicting levels alarm	•	•					
Advanced functions							
Start and stop delays	•	•	•	•		•	•
Motor temperature sensor	•	•	•	•		• ⁴⁾	•
Test run/anti-seizing	•	•	•	•		•	•
Daily emptying (emptying the pit once a day)	•	•					•
Water-in-oil sensor input	•	•					
Communication							
SMS messaging	• ²⁾	• ²⁾	• ¹⁾	• ¹⁾			• ²⁾
SCADA communication (GSM/GPRS)	• ²⁾	• ²⁾					• ⁵⁾
User interface							
Level indication	•	•	•	•			• ⁶⁾
Graphical display	•	•					• ⁶⁾
PC Tool WW Controls	•	•				•	

¹⁾ If an SMS module is fitted.

²⁾ If a CIM 250 GSM/GPRS module is fitted in the CU 361.

³⁾ Built-in pressure sensor and dry-running sensor.

⁴⁾ Built-in, but a Grundfos CIU unit is required to get access to data or setting of parameters.

⁵⁾ Modbus, GSM, GPRS, SMS and GRM options.

⁶⁾ When using a Grundfos R100 remote control.

⁷⁾ Inputs for external sensors (NO or NC).

WebCAPS

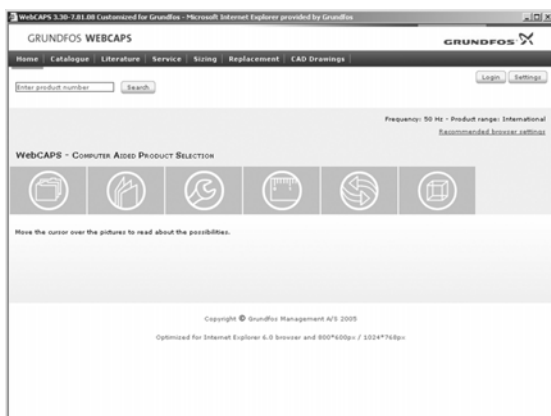

WebCAPS is a **Web-based Computer Aided Product Selection** program available on www.grundfos.com.

WebCAPS contains detailed information on more than 185,000 Grundfos products in more than 20 languages.

In WebCAPS, all information is divided into six sections:

- Catalogue
- Literature
- Service
- Sizing
- Replacement
- CAD drawings.

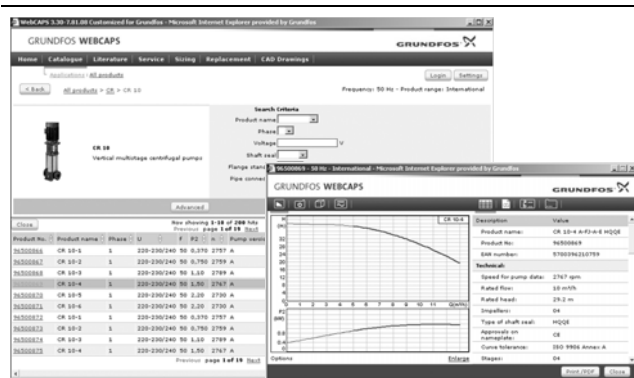

Catalogue

This section is based on fields of application and pump types, and contains

- technical data
- curves (QH, Eta, P1, P2, etc.) which can be adapted to the density and viscosity of the pumped liquid and show the number of pumps in operation
- product photos
- dimensional drawings
- wiring diagrams
- quotation texts, etc.

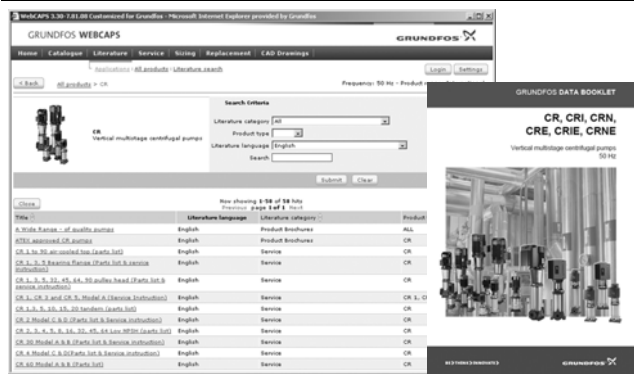

Literature

In this section you can access all the latest documents of a given pump, such as

- data booklets
- installation and operating instructions
- service documentation, such as Service kit catalogue and Service kit instructions
- quick guides
- product brochures.



Service

This section contains an easy-to-use interactive service catalogue. Here you can find and identify service parts of both existing and discontinued Grundfos pumps.

Furthermore, this section contains service videos showing you how to replace service parts.



Sizing

This section is based on different fields of application and installation examples, and gives easy step-by-step instructions in how to

- select the most suitable and efficient pump for your installation
- carry out advanced calculations based on energy consumption, payback periods, load profiles, life cycle costs, etc.
- analyse your selected pump via the built-in life cycle cost tool
- determine the flow velocity in wastewater applications, etc.



Replacement

In this section you find a guide to selecting and comparing replacement data of an installed pump in order to replace the pump with a more efficient Grundfos pump. The section contains replacement data of a wide range of pumps produced by other manufacturers than Grundfos.

Based on an easy step-by-step guide, you can compare Grundfos pumps with the one you have installed on your site. When you have specified the installed pump, the guide will suggest a number of Grundfos pumps which can improve both comfort and efficiency.

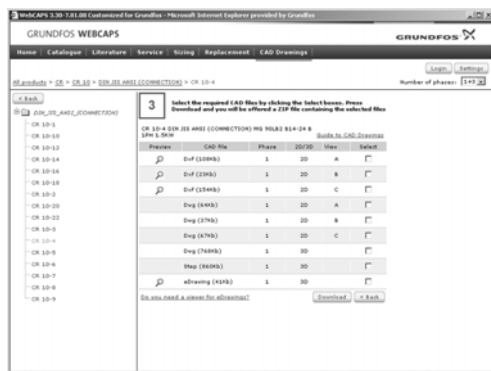

CAD drawings

In this section it is possible to download two-dimensional (2D) and three-dimensional (3D) CAD drawings of most Grundfos pumps.

These formats are available in WebCAPS:

- 2-dimensional drawings:
- .dxf, wireframe drawings
 - .dwg, wireframe drawings.
- 3-dimensional drawings:
- .dwg, wireframe drawings (without surfaces)
 - .stp, solid drawings (with surfaces)
 - .eprt, E-drawings.

WinCAPS



Fig. 30 WinCAPS CD-ROM

WinCAPS is a **Windows-based Computer Aided Product Selection** program containing detailed information on more than 185,000 Grundfos products in more than 20 languages.

The program contains the same features and functions as WebCAPS, but is an ideal solution if no Internet connection is available.

WinCAPS is available on CD-ROM and updated once a year.

Subject to alterations.

97641814 0710
Repl. 97641814 0510

GB

ECM: 1063196

The name Grundfos, the Grundfos logo, and the payoff Be–Think–Innovate are registered trademarks owned by Grundfos Management A/S or Grundfos A/S, Denmark. All rights reserved worldwide.