

Unilift CC, KP, AP

Submersible drainage and effluent pumps
50 Hz



Contents

Product overview

Unilift CC, KP, AP	3
--------------------	---

General data

Performance range	4
Applications	5
Examples of applications	5
Wastewater definitions	5
Pump overview	5
Type keys	6
Construction	7
Installation	7

Technical data

Unilift CC	8
Unilift KP	12
Unilift AP12	16
Unilift AP35	21
Unilift AP35B	26
Unilift AP50	31
Unilift AP50B	36

Controllers

Control box	40
Level controller	40
LC 107, LCD 107	41
LC 108, LCD 108	43
LC 110, LCD 110	45











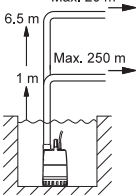

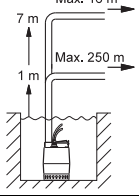
Accessories

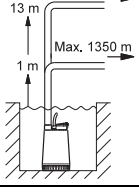
Accessories for Unilift CC, KP, AP pumps	47
Level controllers and accessories	48
Accessories for controllers	50

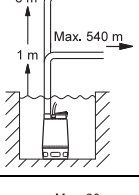
Product range

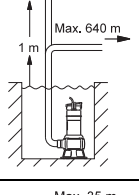
Unilift CC	51
Unilift KP 150	52
Unilift KP 250	53
Unilift KP 350	54
Unilift AP12	55
Unilift AP35	56
Unilift AP35B	56
Unilift AP50	57
Unilift AP50B	57

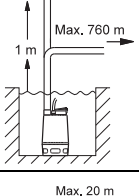
Unilift CC, KP, AP

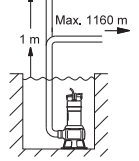
	Application		Technical data	Sizing
Drainage	Unilift CC Unilift CC is a submersible pump designed for pumping clean, non-aggressive water and slightly dirty (grey) wastewater. Unilift CC can pump down to 3 mm water level and can be used in permanent installations or as a portable pump.		GR A0682 <ul style="list-style-type: none"> Max. flow rate, Q: 14 m³/h Max. head, H: 9 m Liquid temp.: 0 °C to +40 °C Max. particle size: Ø10 Material: Composite Low suction to 3 mm. 	 TM03 1883 3305
	Unilift KP Unilift KP is a submersible pump designed for pumping clean, non-aggressive water and slightly dirty (grey) wastewater such as domestic effluents from septic and sludge treating systems.		GR 0110 <ul style="list-style-type: none"> Max. flow rate, Q: 14 m³/h Max. head, H: 9 m Liquid temp.: 0 °C to +50 °C Max. particle size: Ø10 Material: Stainless steel. 	 TM03 1884 3305
	Unilift AP12 Unilift AP12 is a submersible pump designed for pumping clean, non-aggressive water and slightly dirty (grey) wastewater. The pump can be used as a portable unit.		TM03 1851 3205 <ul style="list-style-type: none"> Max. flow rate, Q: 32 m³/h Max. head, H: 17 m Liquid temp.: 0 °C to +55 °C Max. particle size: Ø12 Material: Stainless steel. 	 TM03 1885 3305
Effluent	Unilift AP35 Unilift AP35 is a submersible pump designed for pumping dirty water, untreated wastewater (excluding toilet discharge) and liquids containing fibres from light industry, laundries, etc. with particles up to Ø35.		TM00 5739 1195 <ul style="list-style-type: none"> Max. flow rate, Q: 18 m³/h Max. head, H: 11 m Liquid temp.: 0 °C to +55 °C Max. particle size: Ø35 Material: Stainless steel. 	 TM03 1886 3305
	Unilift AP35B Unilift AP35B is a submersible pump designed for pumping effluents (excluding toilet discharge). The pump is suitable for installation on auto coupling; this allows easy access to the pump for maintenance and other purposes.		TM03 8259 0907 <ul style="list-style-type: none"> Max. flow rate, Q: 21 m³/h Max. head, H: 13 m Liquid temp.: 0 °C to +40 °C Max. particle size: Ø35 Material: Stainless steel Optional: Auto-coupling. 	 TM03 1888 3305
	Unilift AP50 Unilift AP50 is a submersible pump designed for pumping dirty water, untreated wastewater and liquids containing fibres from light industry, laundries, etc. with particles up to Ø50.		TM00 5740 1495 <ul style="list-style-type: none"> Max. flow rate, Q: 32 m³/h Max. head, H: 12 m Liquid temp.: 0 °C to +55 °C Max. particle size: Ø50 Material: Stainless steel. 	 TM03 1887 3305
Domestic sewage	Unilift AP50B Unilift AP50B is a submersible pump designed for pumping effluents. The pump is suitable for installation on auto-coupling allowing easy access to the pump for maintenance and other purposes.		TM03 8260 0907 <ul style="list-style-type: none"> Max. flow rate, Q: 31 m³/h Max. head, H: 17 m Liquid temp.: 0 °C to +40 °C Max. particle size: Ø50 Material: Stainless steel Optional: Auto-coupling. 	 TM03 1889 3305

Performance range

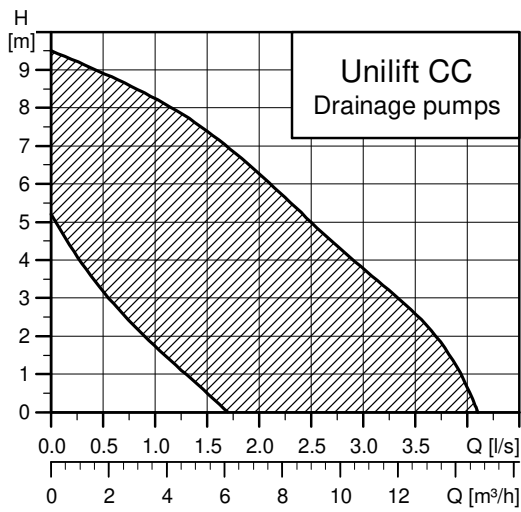

TM03 1364 1805

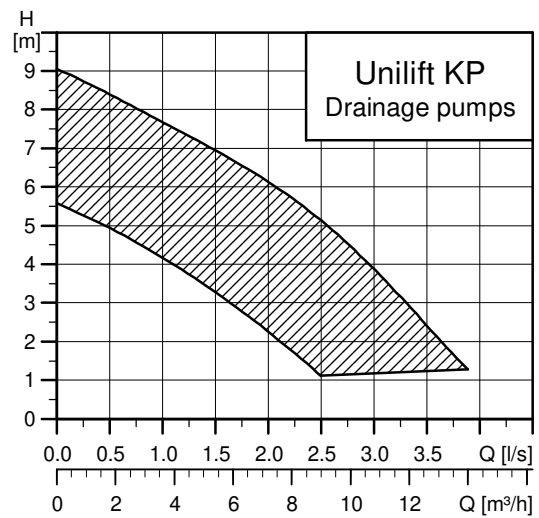

TM03 1363 1805

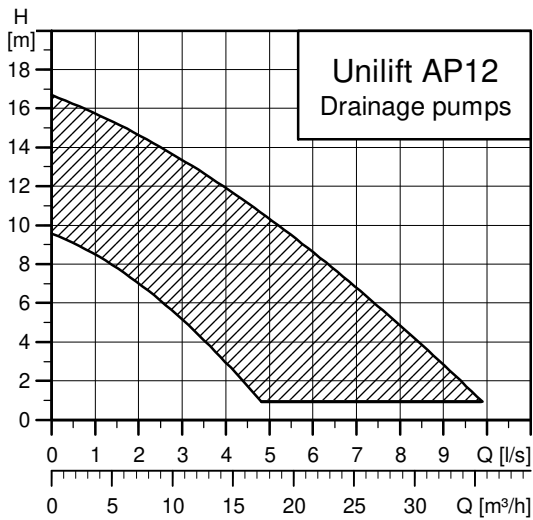

TM03 1362 1805

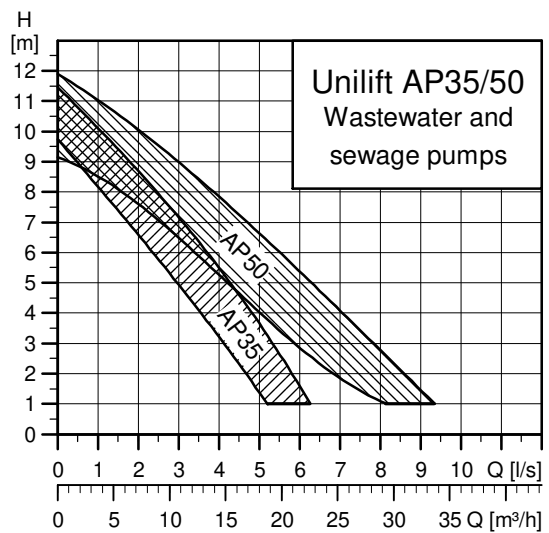

TM00 3547 1805

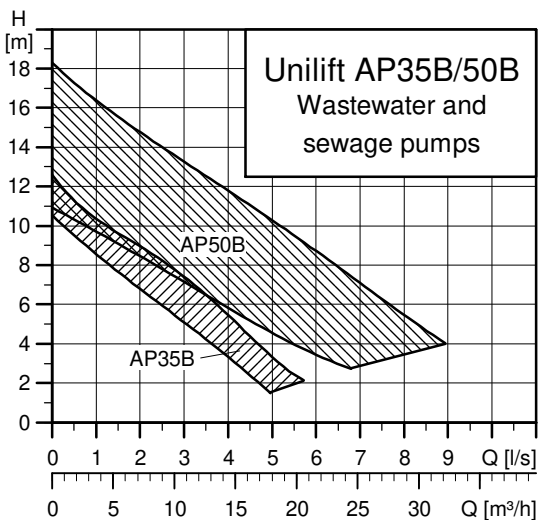

TM01 9544 1805

Applications

The Unilift CC, KP and AP are submersible drainage pumps suitable for temporary as well as permanent free-standing installation. Furthermore, Unilift AP35B and AP50B pumps are suitable for installation on an auto-coupling at the bottom of a collecting tank with guide rails going to the top.

The pumps are designed for intermittent operation.

pH values:

- Unilift CC: 4 to 9
- Unilift KP: 4 to 9
- Unilift AP: 4 to 10.

Maximum density: 1,100 kg/m³.

Maximum installation depth below water level: 10 m.

For permanent installation, level controllers are available: LC 107, LC 108 and LC 110 for one-pump installations and LCD 107, LCD 108 and LCD 110 for two-pump installations.

Examples of applications

Applications	Unilift pump type						
	CC	KP	AP12	AP35	AP35B	AP50	AP50B
Max. liquid temperature	40 °C	50 °C	55 °C	55 °C	40 °C	55 °C	40 °C
Max. particle size [mm]	10	10	12	35	35	50	50
Non-permanent, light-duty applications (used as a portable pump)	●	●	○	○	○	○	○
Non-permanent, heavy-duty applications for installers and light industry (used as a portable pump)			●	●	●	●	●
Pumping of:							
Water and rainwater in horticulture	●	●	●				
Water from rivers and lakes	●	●	●	●	●	●	●
Rainwater, drainage water and water from flooding	●	●	●	●	●	●	●
Water for filling/emptying containers, ponds, tanks, etc.	●	●	●	●	●	●	●
Effluents from showers, washing machines and sinks below sewer level	●	●	●	●	●	●	●
Pool water	●	●	●	●	●	●	●
Ditch drainage water	●	●	●	●	●	●	●
Groundwater (lowering applications)	●	●	●	●	●	●	●
Domestic effluents from septic and sludge-treating systems	○	●	●	●	●	●	●
Liquids containing fibres from light industry, laundries, etc.				●	●	●	●
Effluents from viaducts, underpasses, etc.				●	●	●	●
Drainage water from garage sprinkler systems				○	○	○	○
Domestic wastewater with toilet discharge from pipes and water closets below sewer level, outdoor pump installations						●	●
Domestic wastewater with toilet discharge from pipes and water closets below sewer level, indoor pump installations							Not applicable, use Multilift
● = Recommended pump type							
○ = Alternative pump type							

Wastewater definitions

Drainage

Raw water, drainage and untreated wastewater containing solids no larger than 12 mm from households, farms and small industry.

Effluent

Dirty water and untreated wastewater (excluding toilet discharge), containing fibres and solids no larger than 50 mm from dewatering systems, domestic wastewater systems and small industry.

Sewage

Untreated wastewater and raw sewage containing fibres, textiles and other solids, including toilet discharge from domestic sewage systems, farms and industry.

To avoid clogging, pumps allowing free passage of solids up to 70-80 mm are recommended. Be aware that toilet discharge often contains foreign bodies such as nappies, tampons, toilet rolls, children's toys and toothbrushes.

Pump overview

Pump range Unilift	Free passage [mm]	Impeller type	Number of motor poles
CC	10	Semi-open	2
KP	10	Semi-open	2
AP12	12	Semi-open	2
AP35	35	Vortex	2
AP35B	35	Vortex	2
AP50	50	Vortex	2
AP50B	50	Vortex	2

Type keys

Unilift CC pumps

Example	Unilift	CC	9	A1
Type range				
Type				
Maximum head [m]				
5				
7				
9				
Operation				
A1 = Automatic operation				
M1 = Manual operation				

Unilift KP pumps

Example	Unilift KP	150	A	1
Type range				
Rated motor output, P_2 [W]:				
150				
250				
350				
Level control:				
S = with integrated, electronic sensor (automatic operation)				
A = with float switch (automatic operation)				
M = without level switch (manual operation)				
Motor:				
1 = single-phase				
3 = three-phase				

Unilift AP pumps

Example	Unilift AP	35	B.	50.	08.	A	1	.V
Type range								
Maximum solids size (mm)								
Pump type:								
Blank = AP pump								
B = AP Basic								
Nominal diameter of discharge port								
Power output $P_2 / 100$ [W]								
Level control:								
A = Automatic operation (with float switch)								
Blank = Manual operation (without float switch)								
Motor:								
1 = Single-phase								
3 = Three-phase								
Impeller:								
V = Vortex impeller								

Construction

Vertical, single-stage, submersible centrifugal pumps with horizontal or vertical discharge port designed for free-standing installation, installation by means of an auto-coupling guide rail system or installation in collecting tanks.

The pumps are directly connected to an asynchronous submersible motor for 1 x 230 V +6/-10 %, 3 x 230 V +6/-10 % or 3 x 400 V +6/-10 %, 50 Hz.

Enclosure class: IP 68
Insulation class: B or F.

Unilift pumps

Single-phase pumps incorporate thermal overload protection and require no additional motor protection.

Three-phase pumps must be connected to a motor starter.

Installation

The pumps are suitable for free-standing installation. Unilift AP35B and AP50B can be installed on an auto-coupling guide rail system, available as an accessory.

Pumps for vertical dry tank installation can be installed by means of a stationary stand with suction bend.

Unilift CC



TM03 1358 1805

Fig. 1 Unilift CC

Unilift CC 5, CC 7 and CC 9 pumps are single-stage submersible pumps able to pump down to 3 mm water level. The pumps are designed for pumping rainwater and grey wastewater from:

- washing machines, baths, sinks, etc. from low-lying parts of buildings up to sewer level
- cellars or buildings prone to flooding
- draining wells
- collecting wells for surface water with inlets from roof gutters, tunnels, etc.
- swimming pools, ponds or fountains.

The pumps are suitable for permanent installation or they can be used as portable pumps. They are available in two versions:

- M for manual operation
- A for automatic operation.

The pumps allow free passage of particles up to Ø10 mm.

Approvals

VDE, GOST and LGA according to DIN EN 12050-2.

Pumped liquids

The pumps are suitable for these liquids:

- clean, non-aggressive water
- slightly dirty (grey) wastewater.

The pumps are **not** suitable for these liquids:

- liquids containing long fibres
- inflammable liquids (oil, petrol, etc.)
- aggressive liquids.

If the pump has been used for other liquids than clean water, it should be flushed through with clean water immediately after use.

Components included

The pump is supplied with an adapter and a non-return valve.

The adapter has ¾", 1" and 1¼" external threads. It must be cut to fit the discharge pipe.

The non-return valve can be fitted in the adapter to prevent backflow through the pump when it stops.

Pump sleeve and housing

The pump sleeve is made of composite material cast in one piece with a 1¼" external pipe thread (G) discharge connection. A slot on the handle holds the float switch cable.

The mains cable and float switch cable are introduced into the pump sleeve through hermetically sealed cable entries.

The suction strainer is fitted to the sleeve by giving it a light push, and it can be removed easily by means of a screwdriver or similar tool. The water enters the pump through the holes of the suction strainer preventing the passage of large solids. The large holes also ensure a slow flow into the pump.

Suction to low water level is obtained by removing the strainer.

Motor

The motor is a single-phase, asynchronous, dry-rotor motor. The axial rotor position is secured by means of a ball bearing. The motor is cooled by the pumped liquid around the motor.

	Insulation class	Enclosure class
Unilift CC 5	B	IP68
Unilift CC 7	F	IP68
Unilift CC 9	B	IP68

The motor incorporates automatic overload protection cutting out the motor in case of overload. When cooled to normal temperature, the motor will restart automatically.

Materials

Component	Material	DIN W.-Nr.
Motor sleeve	PP 15 GF	
Pump sleeve	PP 15 GF	
Impeller	PPOm 20 GF	
Suction strainer	Stainless steel class A2	1.4301
V-ring	NBR 50	
O-rings	NBR 70	
Cable	H05RN-F 3G0.75 (CC 5) H07RN-F3G1 (CC 7 - CC 9)	

Selection

The overview below is suitable for the selection of the correct size of Unilift CC pumps used in stationary applications.

The flow velocity through the discharge pipe must be minimum 0.7 m/s to ensure self-cleaning.

Example: A DN 32 discharge pipe with an inner diameter of 26 to 34 mm (depending on local standards) requires a minimum flow velocity of approximately 2 m³/h.

The overview below shows the maximum lengths of combined vertical and horizontal DN 32 discharge pipes.

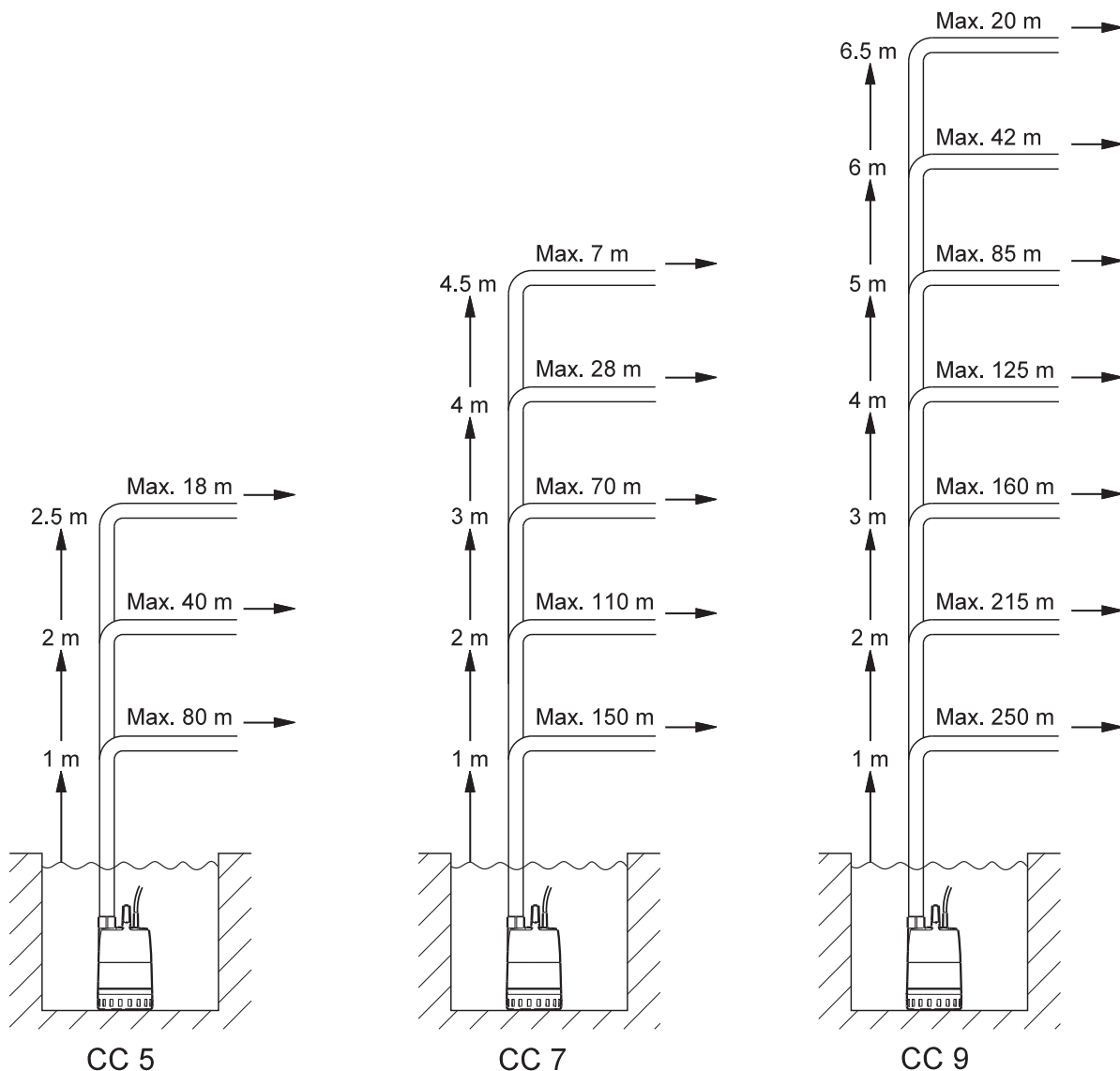

The overview is only intended as a guide. Grundfos is not liable for installations not complying with the overview.

Note: If the non-return valve is used, the pressure drop in the valve is 0.2 m head at 2 m³/h, which is to be subtracted from the vertical pipe lengths.

The vertical height of the discharge pipe should be measured from the pump stop level.

TM03 1370 1805

Performance curves

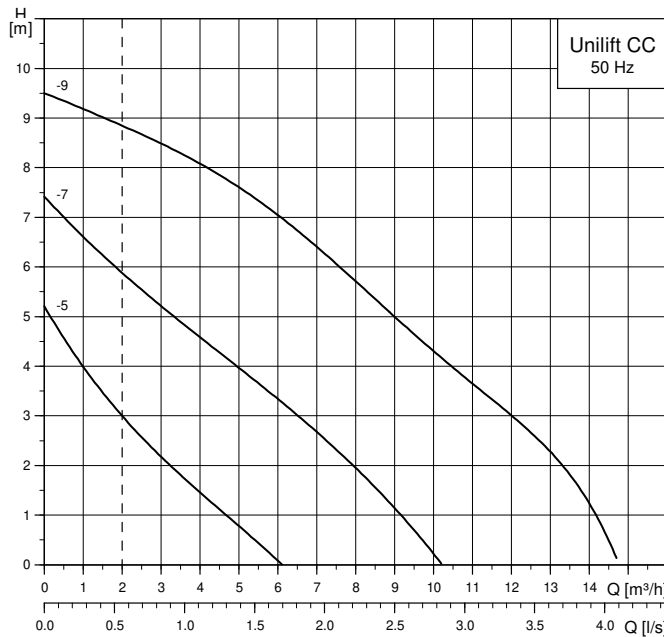

The broken line represents a min. flow velocity of 0.7 m/s with a DN 32 discharge pipe to DIN EN 12056.

TM03 1346 1805

Operating conditions

Liquid temperature

0 °C to +40 °C.

However, at intervals of at least 30 minutes, the pump is allowed to run at maximum +70 °C for periods not exceeding two minutes.

Installation

The pump can be used in the vertical position as well as in the tilted or horizontal position with the discharge port as the highest point of the pump. The suction strainer must be covered by the pumped liquid.

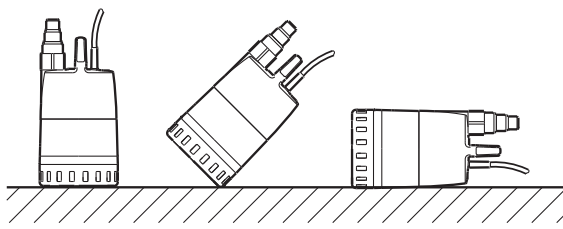

TM00 1111 1005

Fig. 2 Pump positions

Installation depth

Maximum 10 metres below the water surface.

Adjustment of cable length for float switch

The difference in level between start and stop can be adjusted by changing the free cable length between the float switch and the pump handle.

- Increasing the free cable length results in fewer starts/stops and a large difference in level.
- Reducing the free cable length results in more frequent starts/stops and a small difference in level.

In order for the float switch to start and stop the pump, the free cable length must be minimum 100 mm and maximum 200 mm.

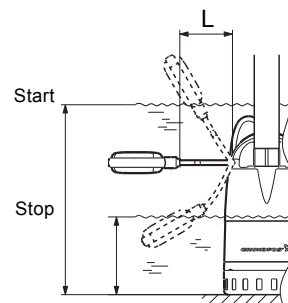

Fig. 3 Start-stop level, Unilift CC

TM03 0829 0505

Pump type	Cable length (L) min. 100 mm		Cable length (L) max. 200 mm	
	Start [mm]	Stop [mm]	Start [mm]	Stop [mm]
Unilift CC 5	350	115	400	55
Unilift CC 7	350	115	400	55
Unilift CC 9	385	150	435	90

Technical data

Pump type	Voltage [V]	P ₁ [W]	I _n [A]	Dimensions [mm]					Weight [kg]
				H	B	H1	B1	B2	
Unilift CC 5	1 x 220/240	240	1.1	520	400	305	160	26.5	4.35
Unilift CC 7	1 x 220/240	380	1.7	520	400	305	160	26.5	4.6
Unilift CC 9	1 x 220-240	780	3.7	570	500	340	160	26.5	6.5

With float switch

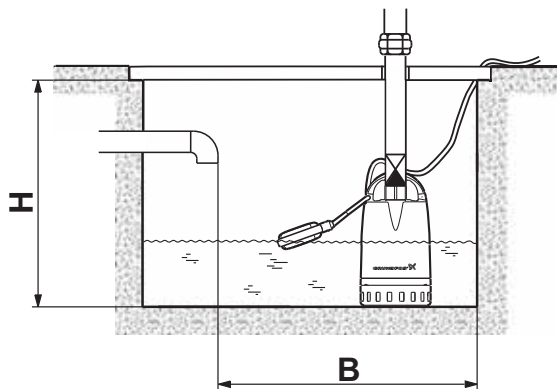

TM03 1122 1105

Fig. 4 Minimum well dimensions, Unilift CC

If the pump is installed in a collecting well, the minimum dimensions of the well should be as shown above to ensure free movability of the float switch.

Without float switch

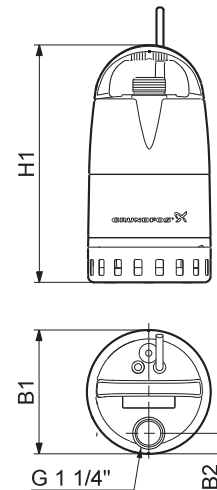

TM03 1357 1805

Fig. 5 Pump dimensions

The space required corresponds to the physical dimensions of the pump.

Unilift KP



TM01 7145 4099

The Unilift KP pump is designed for liquid transfer and drainage of clean or slightly dirty wastewater with the pump completely or partly submerged in the liquid.

The pump is suitable for these applications:

- drainage of cellars or buildings
- pumping of domestic wastewater without toilet waste
- groundwater lowering
- emptying applications, e.g. in pools, tanks and vessels
- pumping applications within agriculture, the dairy industry, horticulture and the process industry.

Approvals

VDE, LGA, UL and CSA.

Pumped liquids

Pumps without level switch or with float switch

The pumps are suitable for these liquids:

- clean, non-aggressive water
- slightly dirty (grey) wastewater.

If the pump has been used for other liquids than clean water, it should be flushed through with clean water immediately after use. The open-impeller construction ensures a free passage of solids up to a diameter of $\varnothing 10$ mm.

Pumps with vertical level switch

The pumps must only be used for the pumping of clean groundwater and drain water.

Operating conditions

Installation depth: Max. 10 m below liquid level
 Min. liquid temperature: 0°C
 Max. liquid temperature at continuous operation: 50°C

During continuous pumping, the suction strainer must always be completely covered by the liquid.

Max. liquid temperature: 70°C for periods not exceeding two minutes at intervals of at least 30 minutes.

Discharge

Unilift KP 150, KP 250 and KP 350: Rp 1¼.

Pump sleeve and housing

Single-stage, submersible, stainless steel, drainage pump in a robust design with upward-pointing discharge port placed on top of the pump.

The water enters the pump through the holes of the suction strainer, preventing the passage of large solids. The sturdy impeller has single-curved vanes with bevelled front edges preventing fibres from jamming the impeller. The guide vanes in the pump housing guide the liquid, lifting sand grains into the liquid flow, thus preventing blocking by sand.

The outer casing is made in one piece. The mains cable and the cable of the level switch are combined in one vulcanized and water-tight plug, which is secured to the socket of the hermetically sealed stator housing.

Motor

The motor is a single- or three-phase asynchronous canned motor with liquid-filled rotor chamber and water-lubricated bearings. The motor is cooled by the pumped liquid around the motor.

Enclosure class: IP 68

Insulation class: F.

The motor incorporates automatic overload protection which cuts out the motor in case of overload. When cooled to normal temperature, the motor restarts automatically.

Materials

Component	Material	DIN W.-Nr.	AISI
Outer casing	Stainless steel	1.4301	304
Pump housing	Stainless steel	1.4301	304
Suction strainer	Stainless steel	1.4301	304
Impeller	Stainless steel	1.4301	304
Shaft	Stainless steel	1.4057	431
Stator housing	Stainless steel	1.4301	304
Guide vanes	Stainless steel	1.4301	304
Bearings	Carbon		
O-rings	NBR		
Seal rings			
Cables	H 07 RN-F		

Selection

The below overview is suitable for the selection of the correct size of Unilift KP pumps used in stationary applications.

The flow velocity through the discharge pipe must be minimum 0.7 m/s to ensure self-cleaning. Example: A DN 32 discharge pipe with an inner diameter of 26 to 34 mm (depending on local standards) requires a minimum flow velocity of approximately 2.3 m³/h.

The overview below shows the maximum lengths of combined vertical and horizontal DN 32 discharge pipes.

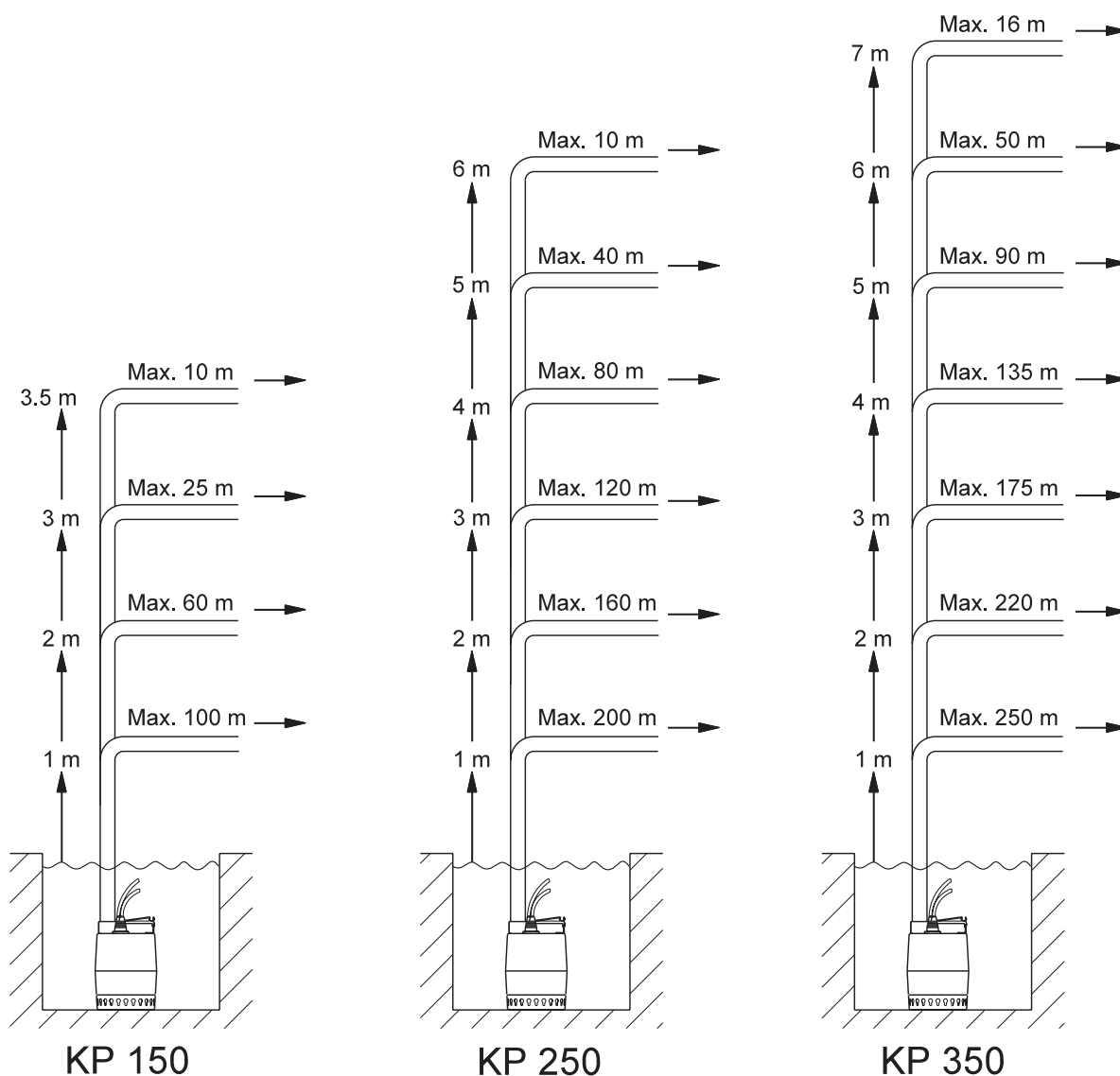

TMM03 1643 2505

The above overview is only intended as a guide. Grundfos is not liable for any faulty installations based on the overview.

Note: If the non-return valve is used, the pressure drop in the valve is 0.2 m head, which is to be subtracted from the vertical pipe lengths.

The vertical height of the discharge pipe should be measured from the pump stop level.

Performance curves

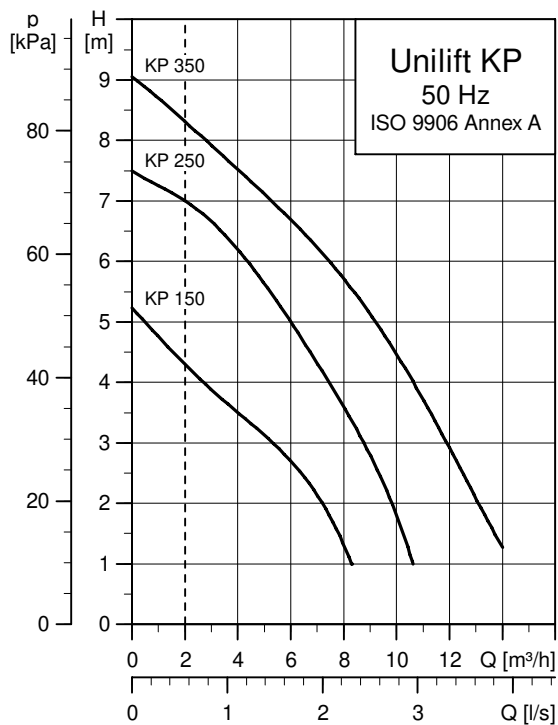

The broken line represents a min. liquid velocity of 0.7 m/s with a DN 32 discharge pipe to DIN EN 12056.

TM03 1583 2505

Pump type	Voltage [V]	P ₁ [W]	I _n [A]	Dimensions [mm]						Weight [kg]
				H	B1	B2	L1	L2	L3	
Unilift KP 150	1 x 220-230	300	1.3	225	149	31	350	400	70	6.3
Unilift KP 150	1 x 230-240	300	1.3	225	149	31	350	400	70	6.3
Unilift KP 250	1 x 220-230	480	2.3	225	149	31	350	400	70	7.2
Unilift KP 250	1 x 230-240	480	2.2	225	149	31	350	400	70	7.2
Unilift KP 250	3 x 380-415	480	0.8	225	149	31	350	400	70	7.2
Unilift KP 350	1 x 220-240	700	3.2	235	149	31	350	410	70	8.0
Unilift KP 350	3 x 380-400	700	1.3	235	149	31	350	410	70	8.0

With float switch

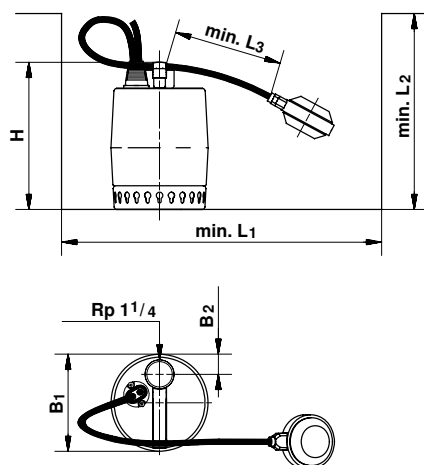

TM00 1803 1597

With vertical level switch

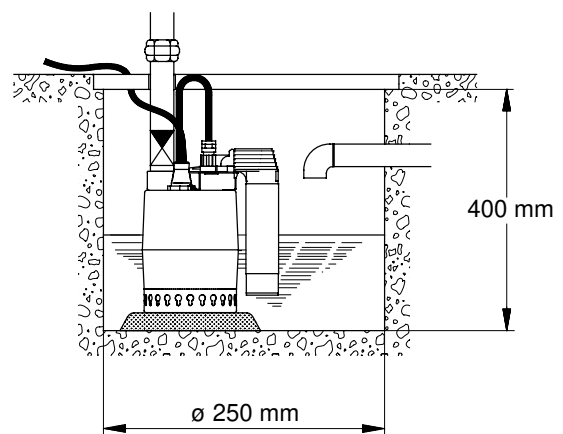

TM01 1109 1098

Installation

Pumps without level switch or with float switch can be used in vertical position with the discharge port uppermost or in horizontal or tilted position with the discharge port as the highest point of the pump.

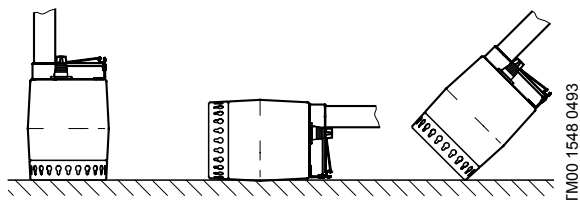

Pumps with vertical level switch must be used in the vertical position.

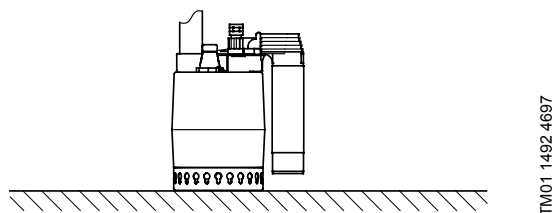

The Unilift KP pump with vertical level switch is well suited for permanent installation.

Level switches

A level switch, which gives impulses to start/stop between two levels of liquid, is connected to pumps intended for automatic operation. This type of installation requires a non-return valve in the discharge pipe or pump. The pumps are available with two different types of level switches.

Minimum liquid level

- manual operation: 14 mm
- automatic operation: See below.

Pumps with float switch

A clamp on the handle of the pump holds the cable of the level switch. The difference in level between start and stop can be adjusted by changing the free cable length between the handle of the pump and the level switch.

Dimensions for Unilift KP 350 are marked with an "★".

Float switch

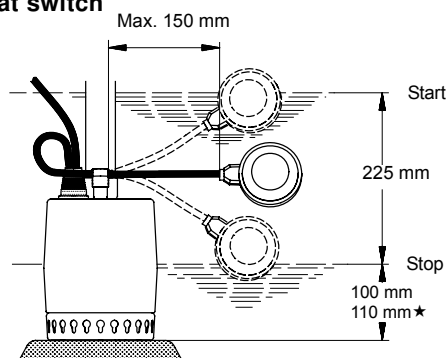

Pumps with vertical level switch

For pumps with vertical level switch, the difference in level between start and stop is not adjustable.

Dimensions for Unilift KP 350 are marked with an "★".

Vertical level switch

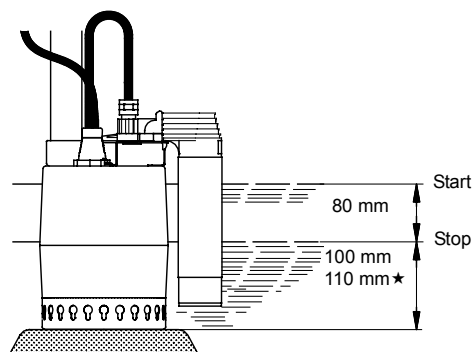

Unilift AP12



TM00 5738 0895

Fig. 13 Unilift AP12

The Unilift AP12 pump is a single-stage submersible pump designed for pumping drainage water.

The pump is suitable for these applications:

- groundwater lowering
- pumping in drainage collecting wells
- pumping in surface water collecting wells with inflow from roof gutters, shafts, tunnels, etc.
- emptying ponds, tanks, etc.

Maximum particle size: 12 mm.

Liquid temperature range: 0 °C to +55 °C.

Approvals

VDE, LGA, UL and CSA.

Automatic operation

The pump is available for automatic as well as manual operation and can be installed in a permanent installation or used as a portable pump. The pump is available in these versions:

- with float switch fitted for automatic on/off operation between two liquid levels (single-phase pumps)
- with separate level switch and control box for automatic on/off operation between two liquid levels (three-phase pumps)
- without level switch for manual on/off operation.

Pumps fitted with float switch can also be used for manual on/off operation. In this case, the float switch must be secured in an upward-pointing position.

Pump sleeve and housing

The stainless steel pump sleeve is made in one piece and equipped with an insulated carrying handle. The suction strainer is clipped on to the pump housing for easy removal in connection with maintenance. The strainer prevents the passage of large solids and ensures a slow flow into the pump. As a result, most impurities are prevented from entering the pump.

The stainless steel pump housing is fitted with an internal riser pipe ensuring high efficiency.

The riser pipe has a number of holes enabling efficient cooling of the motor during operation. The cable entry is of the socket and plug connection type for quick and easy dismantling.

Discharge port

All Unilift AP12 pumps have a threaded vertical discharge port.

Unilift AP12.40: Rp 1½

Unilift AP12.50: Rp 2.

Shaft and bearings

The stainless steel shaft rotates in maintenance-free prelubricated ball bearings.

Impeller

The stainless steel impeller is a semi-open impeller with L-shaped blades and a clearance of 12 mm. The blades are curved backwards to reduce any harmful effect from solid particles and to minimise power consumption.

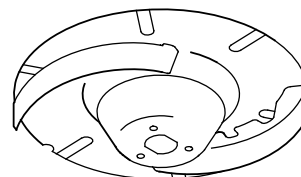

TM00 5477 0895

Fig. 14 Impeller, Unilift AP12

Shaft seal

The shaft seal is a combination of a mechanical bellows shaft seal and a lip seal with 60 ml oil between. Seal faces are made of silicone carbide.

Motor

The motor is a single- or three-phase asynchronous dry-rotor motor.

Enclosure class: IP68

Insulation class: F (155 °C)

Cable type: H07RN-F.

Single-phase motors have built-in thermal protection.

Materials

Component	Material	DIN W.-Nr.	AISI
Pump housing	Stainless steel	1.4301	304
Riser pipe	Stainless steel	1.4301	304
Impeller	Stainless steel	1.4301	304
Pump sleeve	Stainless steel	1.4401	316
Pump shaft - wet end	Stainless steel	1.4301	304
Bearings	Heavy-duty prelubricated ball bearings		
O-rings	NBR rubber		
Screws	Stainless steel	1.4301	304
Oil	Shell Ondina 15, non-toxic		

Selection

The overview below is suitable for the selection of the correct size of Unilift AP12 pumps used in stationary applications.

To ensure that the discharge pipe is self-cleaning, the calculation of the pipe lengths is based on these requirements:

- use steel pipes
- the minimum flow velocity through the vertical discharge pipe must be 1 m/s (1½" for AP12.40.xx and 2" for AP12.50.11)
- the minimum flow velocity through the horizontal discharge pipe must be 0.7 m/s (2" for AP12.40.xx and 2½" for AP12.50.11).

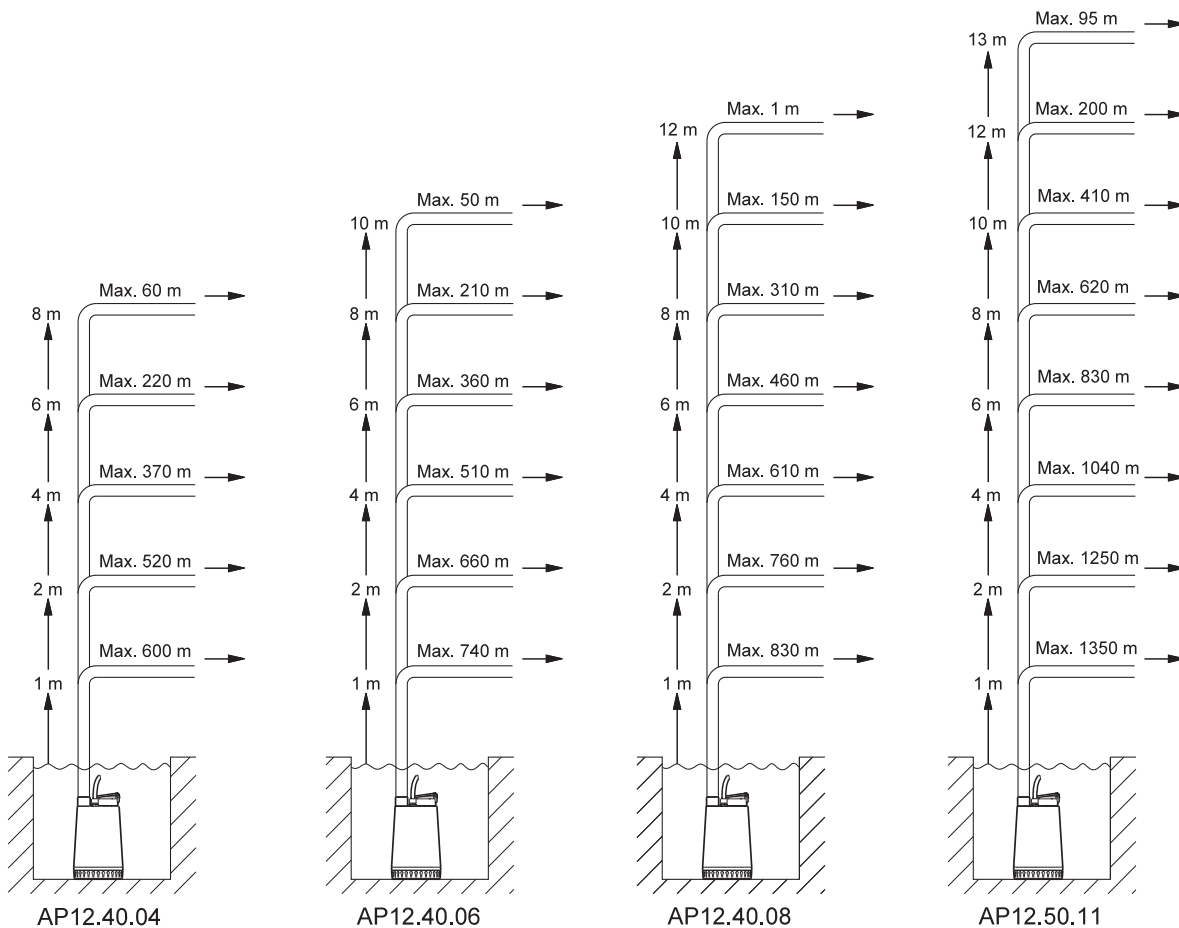

The overview is only intended as a guide. Grundfos is not liable for installations not complying with the overview.

Note: If the non-return valve is used, the pressure drop in the valve is 0.2 m head, which is to be subtracted from the vertical pipe lengths.

The vertical height of the discharge pipe should be measured from the pump stop level.

TM03 1878 3305

Performance curves

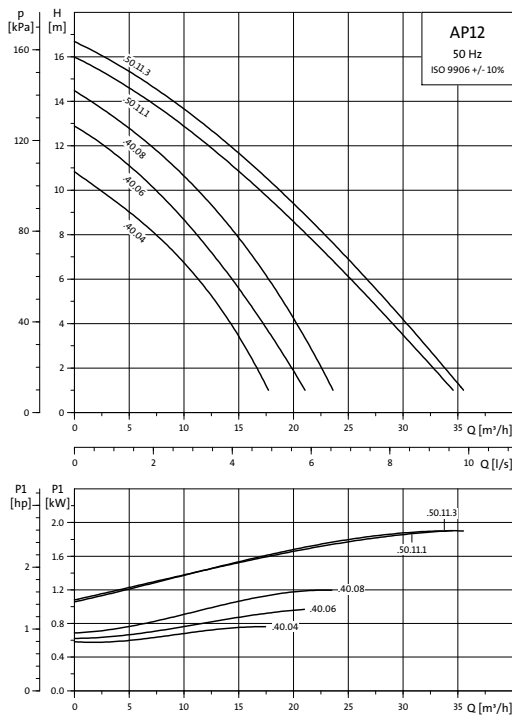

TM00 7212 0803

Dimensional sketch

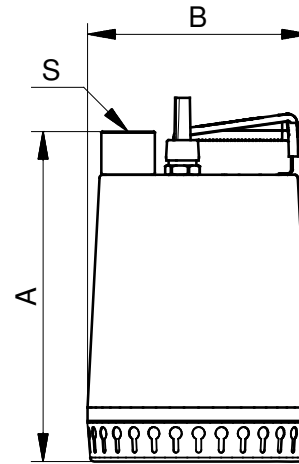

TM00 5523 0995

Fig. 15 Pump dimensions

Pump type	Voltage [V]	P ₁ [kW]	P ₂ [kW]	I _n [A]	Cos φ	I _{start} /I _n	Dimensions [mm]			Weight [kg]
							A	B	S	
Unilift AP12.40.04.1	1 x 230	0.7	0.4	3.0	0.99	3.8	321	216	Rp 1½	11.0
Unilift AP12.40.04.A.1	1 x 230	0.7	0.4	3.0	0.99	3.8	321	216	Rp 1½	11.0
Unilift AP12.40.04.3	3 x 230	0.7	0.4	2.2	0.85	4.7	321	216	Rp 1½	9.7
Unilift AP12.40.04.A.3	3 x 230	0.7	0.4	2.2	0.85	4.7	321	216	Rp 1½	12.0
Unilift AP12.40.04.3	3 x 400	0.7	0.4	1.2	0.83	5.0	321	216	Rp 1½	9.7
Unilift AP12.40.04.A.3	3 x 400	0.7	0.4	1.2	0.83	5.0	321	216	Rp 1½	12.0
Unilift AP12.40.06.1	1 x 230	0.9	0.6	4.4	0.99	3.8	321	216	Rp 1½	11.0
Unilift AP12.40.06.A.1	1 x 230	0.9	0.6	4.4	0.99	3.8	321	216	Rp 1½	11.0
Unilift AP12.40.06.3	3 x 230	0.9	0.6	2.9	0.83	5.4	321	216	Rp 1½	10.7
Unilift AP12.40.06.A.3	3 x 230	0.9	0.6	2.9	0.83	5.4	321	216	Rp 1½	13.0
Unilift AP12.40.06.3	3 x 400	0.9	0.6	1.6	0.83	4.8	321	216	Rp 1½	10.7
Unilift AP12.40.06.A.3	3 x 400	0.9	0.6	1.6	0.83	4.8	321	216	Rp 1½	10.7
Unilift AP12.40.08.1	1 x 230	1.3	0.8	5.9	0.99	3.8	346	216	Rp 1½	12.6
Unilift AP12.40.08.A.1	1 x 230	1.3	0.8	5.9	0.99	3.8	346	216	Rp 1½	12.6
Unilift AP12.40.08.3	3 x 230	1.2	0.8	3.7	0.85	4.7	346	216	Rp 1½	12.0
Unilift AP12.40.08.A.3	3 x 230	1.2	0.8	3.7	0.85	4.7	346	216	Rp 1½	14.3
Unilift AP12.40.08.3	3 x 400	1.2	0.8	2.1	0.87	4.9	346	216	Rp 1½	12.0
Unilift AP12.40.08.A.3	3 x 400	1.2	0.8	2.1	0.87	4.9	346	216	Rp 1½	14.3
Unilift AP12.50.11.1	1 x 230	1.7	1.1	8.5	0.92	3.8	357	241	Rp 2	15.1
Unilift AP12.50.11.A.1	1 x 230	1.7	1.1	8.5	0.92	3.8	357	241	Rp 2	15.1
Unilift AP12.50.11.3	3 x 230	1.9	1.1	6.4	0.85	3.6	357	241	Rp 2	15.6
Unilift AP12.50.11.A.3	3 x 230	1.9	1.1	6.4	0.85	3.6	357	241	Rp 2	17.9
Unilift AP12.50.11.3	3 x 400	1.9	1.1	3.2	0.88	4.6	357	241	Rp 2	15.6
Unilift AP12.50.11.A.3	3 x 400	1.9	1.1	3.2	0.88	4.6	357	241	Rp 2	17.9

Unilift AP12 installations

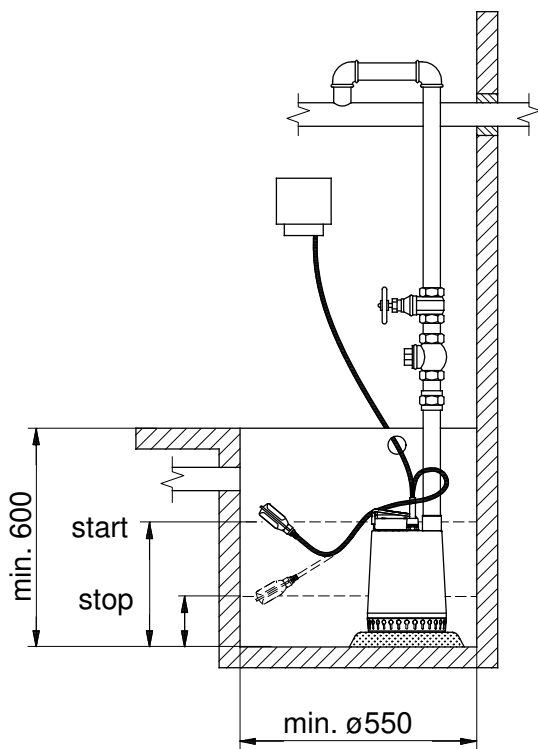

Fig. 16 One-pump installation with float switch

Adjustment of cable length for float switch

The difference in level between start and stop can be adjusted by changing the free cable length between the float switch and the pump handle.

- Increasing the free cable length results in fewer starts/stops and a large difference in level.
- Reducing the free cable length results in more starts/stops and a small difference in level.

In order for the float switch to start and stop the pump, the free cable length must be min. 100 mm and max. 350 mm.

Pump type	Cable length min. 100 mm		Cable length max. 350 mm	
	Start [mm]	Stop [mm]	Start [mm]	Stop [mm]
Unilift AP12	500	300	550	100

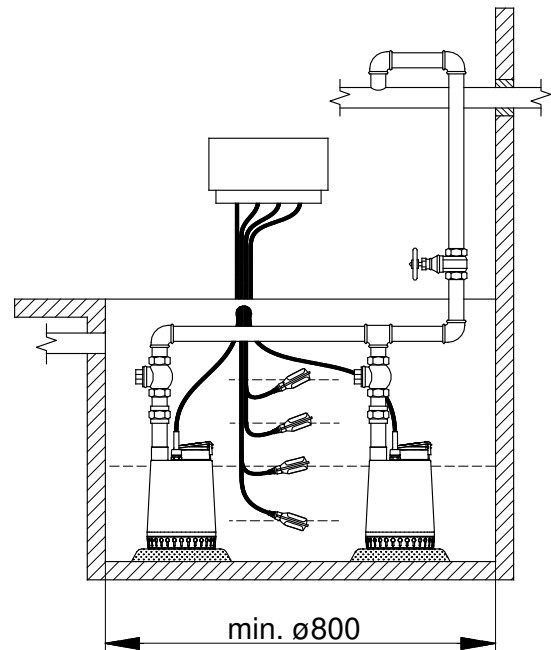

Fig. 17 Two-pump installation with four float switches

Two-pump installation

The Unilift AP pumps can be used for parallel installation together with a controller.

The example shows an installation with four float switches. The pumps are controlled by the liquid level in the tank.

When the liquid lifts up the second float switch from the bottom, the first pump will start.

If the liquid rises faster than one pump can manage, the third float switch from the bottom will be lifted up and start the second pump.

When the the bottom float switch is no longer lifted up by the liquid, the settable stop delay will set in and after that both pumps will be stopped.

When the top float switch is lifted up by the liquid, the high-level alarm will be activated

Unilift AP35



TM00 5739 1195

Fig. 18 Unilift AP35

The Unilift AP35 pump is a single-stage, submersible pump designed for pumping drainage water and effluent. The pump is suitable for these applications:

- groundwater lowering
- pumping in drainage collecting wells
- pumping in surface water collecting wells with inflow from roof gutters, shafts, tunnels, etc.
- emptying of ponds, tanks, etc.
- pumping of fibre-containing wastewater from laundries and industries
- pumping of domestic wastewater without discharge from water closets.

Liquid temperature range: 0 °C to +55 °C.

Approvals

VDE, LGA, UL and CSA.

Automatic operation

The pump is available for automatic as well as manual operation and can be installed in a permanent installation or used as a portable pump. The pump is available in these versions:

- with float switch fitted for automatic on/off operation between two liquid levels (single-phase pumps)
- with separate level switch and control box for automatic on/off operation between two liquid levels (three-phase pumps)
- without level switch for manual on/off operation.

Pumps fitted with float switch can also be used for manual on/off operation. In this case the float switch must be secured in an upward-pointing position.

Pump sleeve and housing

The stainless steel pump sleeve is made in one piece and equipped with an insulated carrying handle.

The suction strainer is clipped on to the pump housing for easy removal in connection with maintenance. The strainer prevents the passage of large solids and ensures a slow flow into the pump.

The stainless steel pump housing is fitted with an internal riser pipe ensuring high efficiency. The riser pipe has a number of holes enabling efficient cooling of the motor during operation. The cable entry is of the socket and plug connection type, allowing for quick and easy dismantling.

Discharge port

All Unilift AP35 pumps have a threaded Rp 1½ vertical discharge port.

Shaft and bearings

The stainless steel shaft rotates in maintenance-free prelubricated ball bearings.

Impeller

The stainless steel impeller is a vortex impeller with L-shaped blades and a clearance of 35 mm in the pump housing. The blades are curved backwards to reduce any harmful effect from solid particles and to minimise power consumption. The impeller has a protective cap to prevent the deposit of long-fibred material.

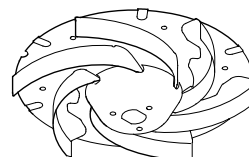

TM00 5478 0895

Fig. 19 Impeller, Unilift AP35

Shaft seal

The shaft seal is a combination of a mechanical, bellows shaft seal and a lip seal with 60 ml oil between. Seal faces are made of silicone carbide.

Motor cable

The motor is a single- or three-phase asynchronous dry-rotor motor.

Enclosure class: IP68
 Insulation class: F (155 °C)
 Cable typea: H07RN-F.

Single-phase motors have built-in thermal protection.

Materials

Component	Materials	DIN W.-Nr.	AISI
Pump housing	Stainless steel	1.4301	304
Riser pipe	Stainless steel	1.4301	304
Impeller	Stainless steel	1.4301	304
Pump sleeve	Stainless steel	1.4401	316
Pump shaft - wet end	Stainless steel	1.4301	304
Bearings	Heavy-duty prelubricated ball bearings		
O-rings	NBR rubber		
Screws	Stainless steel	1.4301	304
Cables	Neoprene		
Oil	Shell Ondina 15, non-toxic		

Selection

The overview below is suitable for the selection of the correct size of Unilift AP35 pumps used in stationary applications.

To ensure that the discharge pipe is self-cleaning, the calculation of the pipe lengths is based on these requirements:

- use steel pipes
- the minimum flow velocity through the vertical discharge pipe (1½") must be 1 m/s
- the minimum flow velocity through the horizontal discharge pipe (2") must be 0.7 m/s.

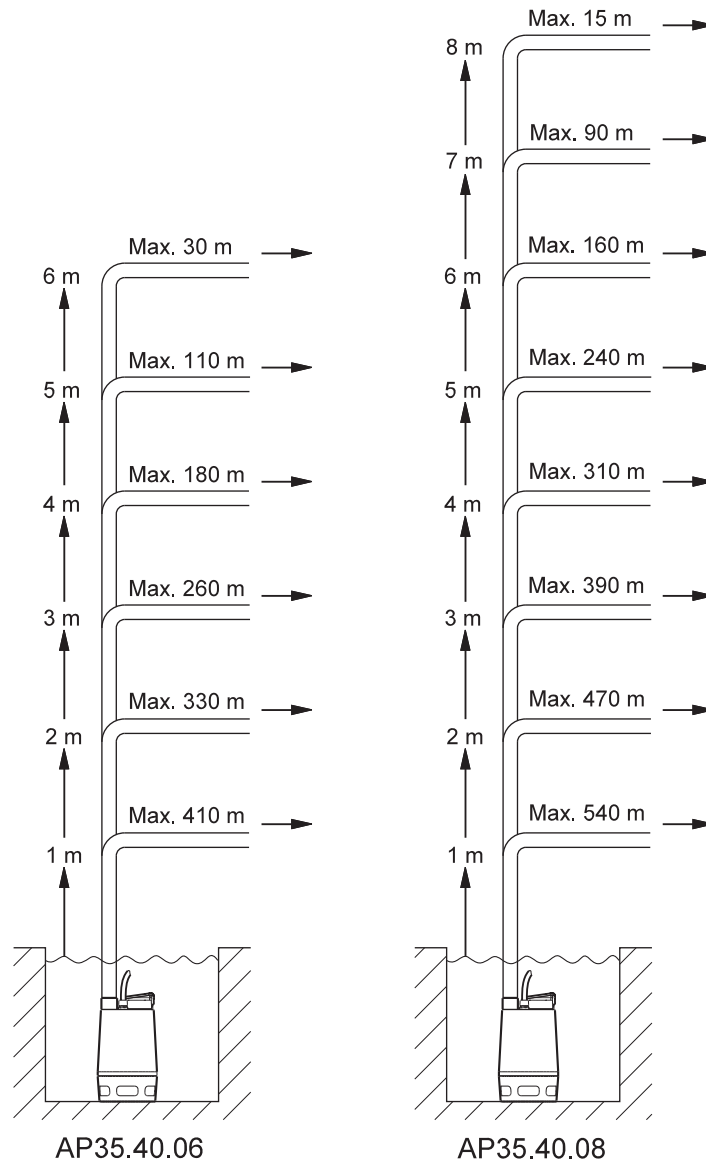

The overview is only intended as a guide. Grundfos is not liable for installations not complying with the overview.

Note: If the non-return valve is used, the pressure drop in the valve is 0.2 m head, which is to be subtracted from the vertical pipe lengths.

The vertical height of the discharge pipe should be measured from the pump stop level.

TM03 1879 3305

Performance curves

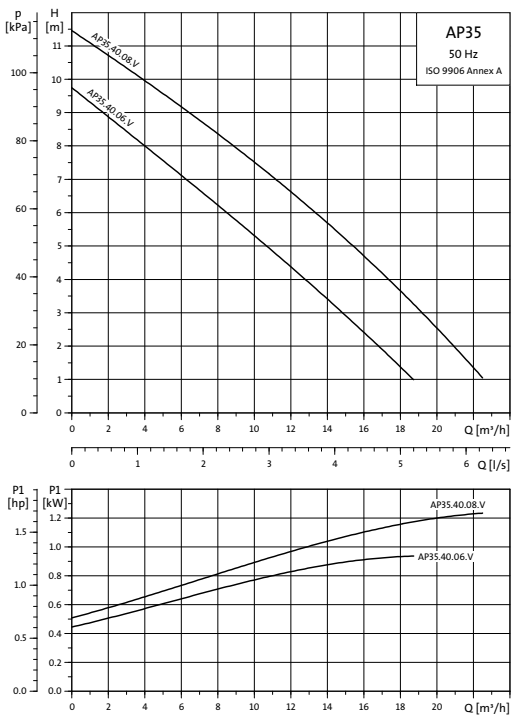

Dimensional sketch

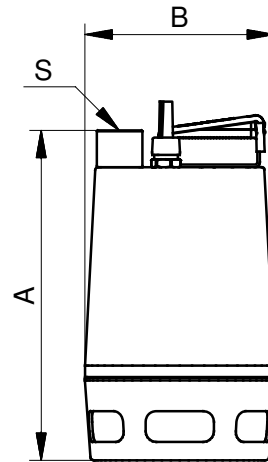

Fig. 20 Pump dimensions

Pump type	Voltage [V]	P ₁ [kW]	P ₂ [kW]	I _n [A]	Cos φ	I _{start} / I _n	Dimensions [mm]			Weight [kg]
							A	B	S	
Unilift AP35.40.06.1.V	1 x 230	0.9	0.6	4.0	0.97	4.1	376	216	Rp 1½	11.4
Unilift AP35.40.06.A.1.V	1 x 230	0.9	0.6	4.0	0.97	4.1	376	216	Rp 1½	11.4
Unilift AP35.40.06.3.V	3 x 230	0.9	0.6	3.0	0.85	5.2	376	216	Rp 1½	11.1
Unilift AP35.40.06.A.3.V	3 x 230	0.9	0.6	3.0	0.85	5.2	376	216	Rp 1½	13.4
Unilift AP35.40.06.3.V	3 x 400	0.9	0.6	1.6	0.83	4.8	376	216	Rp 1½	11.1
Unilift AP35.40.06.A.3.V	3 x 400	0.9	0.6	1.6	0.83	4.8	376	216	Rp 1½	13.4
Unilift AP35.40.08.1.V	1 x 230	1.2	0.7	5.5	0.98	4.0	410	216	Rp 1½	12.7
Unilift AP35.40.08.A.1.V	1 x 230	1.2	0.7	5.5	0.98	4.0	410	216	Rp 1½	12.7
Unilift AP35.40.08.3.V	3 x 230	1.1	0.7	3.6	0.85	5.3	410	216	Rp 1½	12.1
Unilift AP35.40.08.A.3.V	3 x 230	1.1	0.7	3.6	0.85	5.3	410	216	Rp 1½	14.4
Unilift AP35.40.08.3.V	3 x 400	1.1	0.7	2.0	0.86	5.1	410	216	Rp 1½	12.1
Unilift AP35.40.08.A.3.V	3 x 400	1.1	0.7	2.0	0.86	5.1	410	216	Rp 1½	14.4

Unilift AP35 installations

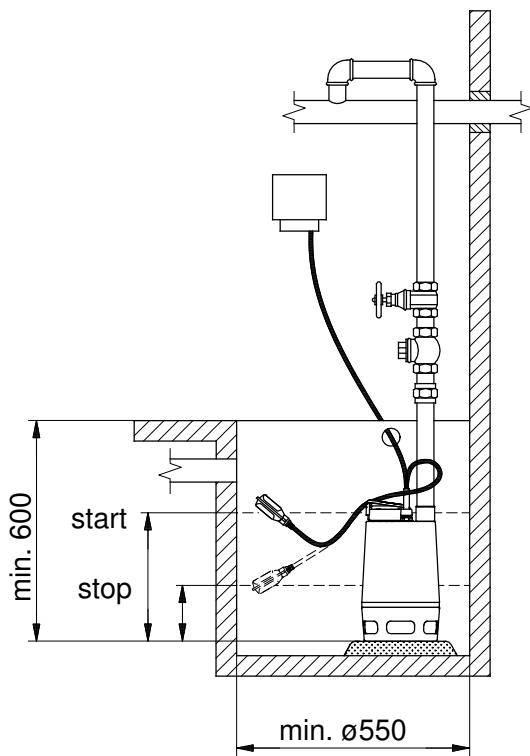

Fig. 21 One-pump installation with float switch

Adjustment of cable length for float switch

The difference in level between start and stop can be adjusted by changing the free cable length between the float switch and the pump handle.

- Increasing the free cable length results in fewer starts/stops and a large difference in level.
- Reducing the free cable length results in more starts/stops and a small difference in level.

In order for the float switch to start and stop the pump, the free cable length must be min. 100 mm and max. 350 mm.

Pump type	Cable length min. 100 mm		Cable length max. 350 mm	
	Start [mm]	Stop [mm]	Start [mm]	Stop [mm]
Unilift AP35	500	300	550	100

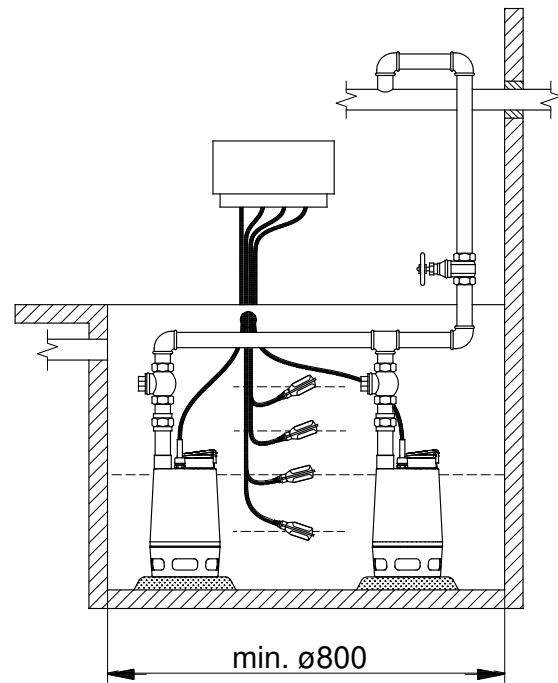

Fig. 22 Two-pump installation with four float switches

Two-pump installation

The Unilift AP pumps can be used for parallel installation together with a controller.

The example shows an installation with four float switches. The pumps are controlled by the liquid level in the tank.

When the liquid lifts up the second float switch from the bottom, the first pump will start.

If the liquid rises faster than one pump can manage, the third float switch from the bottom will be lifted up and start the second pump.

When the the bottom float switch is no longer lifted up by the liquid, the settable stop delay will set in and after that both pumps will be stopped.

When the top float switch is lifted up by the liquid, the high-level alarm will be activated.

Unilift AP35B



TM03 8259 0907

Fig. 23 Unilift AP35B

The Unilift AP35B pump is a single-stage submersible pump designed for pumping effluent.

The pump is suitable for these applications:

- groundwater lowering
- pumping in drainage collecting wells
- pumping in surface water collecting wells with inflow from roof gutters, shafts, tunnels, etc.
- emptying of ponds, tanks, etc.
- pumping of fibre-containing effluent from laundries and industries
- pumping of domestic effluent from septic tanks and sludge treating systems
- pumping of domestic effluent without discharge from water closets.

Liquid temperature range: 0 °C to +40 °C.

Automatic operation

The pump is available for automatic as well as manual operation and can be installed in a permanent installation or used as a portable pump. The pump is available in these versions:

- with float switch fitted for automatic on/off operation between two liquid levels (single-phase pumps)
- without level switch for manual on/off operation.

Pumps fitted with float switch can also be used for manual on/off operation. In this case, the float switch must be secured in an upward-pointing position.

Pump housing

Pump housing with an outstanding design for submersible wastewater pumps, resulting in a high head.

The pump housing is made of a steel tube with a smooth surface and a hydraulically correct shape ensuring free passage of particles.

Ring stand, pump inlet and pump housing are fastened to the motor by means of four springs enabling quick and easy dismantling.

Discharge port

All Unilift AP35B pumps have a threaded R 2 horizontal discharge port.

Shaft and bearings

The stainless steel shaft rotates in maintenance-free prelubricated ball bearings.

Impeller

The stainless steel impeller is a vortex impeller with L-shaped blades and a clearance of 35 mm in the pump housing. The blades are curved backwards to reduce any harmful effect from solid particles and to minimise power consumption. The impeller has a protective cap to prevent the deposit of long-fibred material.

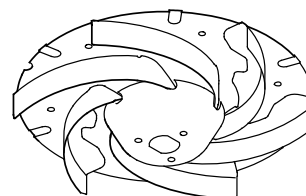

TM00 5478 0895

Fig. 24 Impeller, Unilift AP35B

Shaft seal

The shaft seal is a combination of a mechanical, bellows shaft seal and a lip seal with 80 ml oil between. Seal faces are made of silicone carbide.

Motor cable

The motor is a single- or three-phase asynchronous dry-rotor motor.

Enclosure class:	IP68
Insulation class:	F (155 °C)
Cable type:	H07RN-F.

Single-phase motors have built-in thermal protection.

Materials

Component	Material	DIN W.-Nr.	AISI
Pump housing	Stainless steel	1.4301	304
Impeller	Stainless steel	1.4301	304
Washer	Stainless steel	1.4301	304
Protective cap	Novolen 2360 Kx		
Motor unit complete	Parts in contact with liquid: Stainless steel	1.4401	316
Pump shaft - wet end	Stainless steel	1.4301	304
Motor cable	Neoprene		
O-rings	NBR rubber		
Spring	Stainless steel	1.4310	
Pump inlet	Stainless steel	1.4301	304
Ring stand	Polycarbonate		
Oil	Shell Ondina 15, non-toxic		

Selection

The overview below is suitable for the selection of the correct size of Unilift AP35B pumps used in stationary applications.

To ensure that the discharge pipe is self-cleaning, the calculation of the pipe lengths is based on these requirements:

- use steel pipes
- the minimum flow velocity through the vertical discharge pipe (2") must be 1 m/s
- the minimum flow velocity through the horizontal discharge pipe (2½") must be 0.7 m/s.

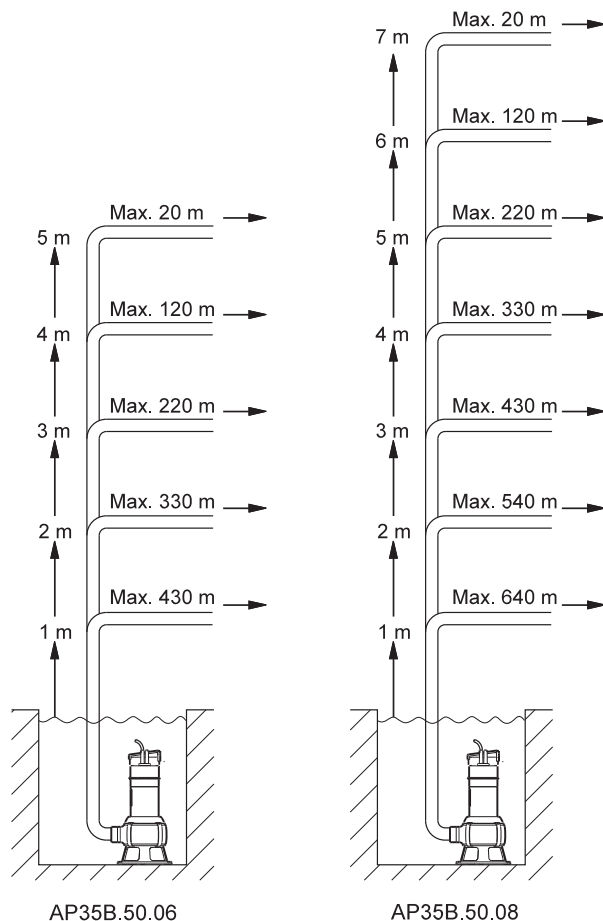

The overview is only intended as a guide. Grundfos is not liable for installations not complying with the overview.

The vertical height of the discharge pipe should be measured from the pump stop level.

TM03 1881 3305

Performance curves

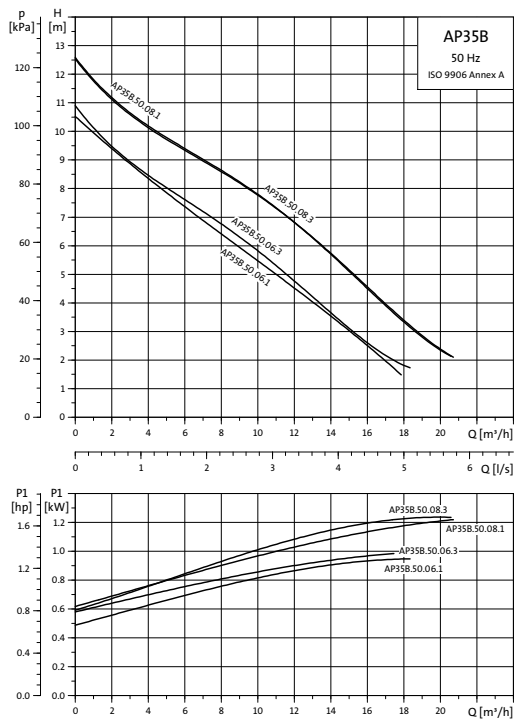

Dimensional sketch

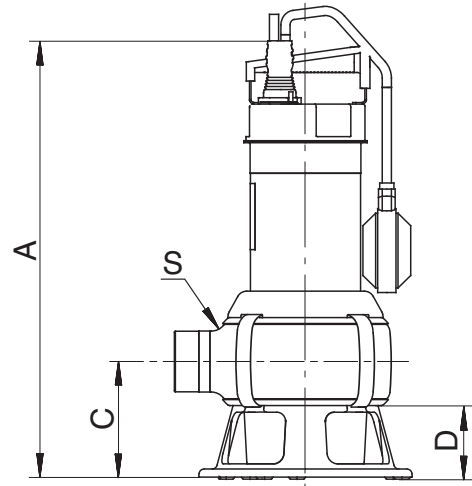

Fig. 25 Pump dimensions

Pump type	Voltage [V]	P ₁ [kW]	P ₂ [kW]	I _n [A]	Cos φ	C [μF]	I _{start} / I _n	Dimensions [mm]				Weight [kg]	Cable length and plug
								A	C	D	S		
Unilift AP35B.50.06.A1.V	1 x 230	1.0	0.66	4.4	0.98	3.1	13.8	443	116	73	R 2	8.5	5 m with Schuko plug
Unilift AP35B.50.06.1.V	1 x 230	1.0	0.66	4.4	0.98	3.1	13.8	443	116	73	R 2	8.5	10 m with Schuko plug
Unilift AP35B.50.06.3.V	3 x 400	1.0	0.63	1.55	0.89	5.2	8.0	443	116	73	R 2	7.4	5 m without plug
Unilift AP35B.50.08.A1.V	1 x 230	1.25	0.71	5.44	0.98	3.4	18.4	468	116	73	R 2	10.0	5 m with Schuko plug
Unilift AP35B.50.08.1.V	1 x 230	1.25	0.71	5.44	0.98	3.4	18.4	468	116	73	R 2	10.0	10 m with Schuko plug
Unilift AP35B.50.08.3.V	3 x 400	1.25	0.78	1.98	0.89	5.4	10.6	468	116	73	R 2	8.4	5 m without plug

Start/stop level

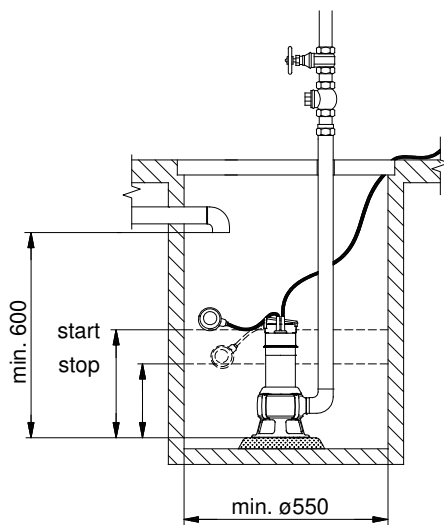
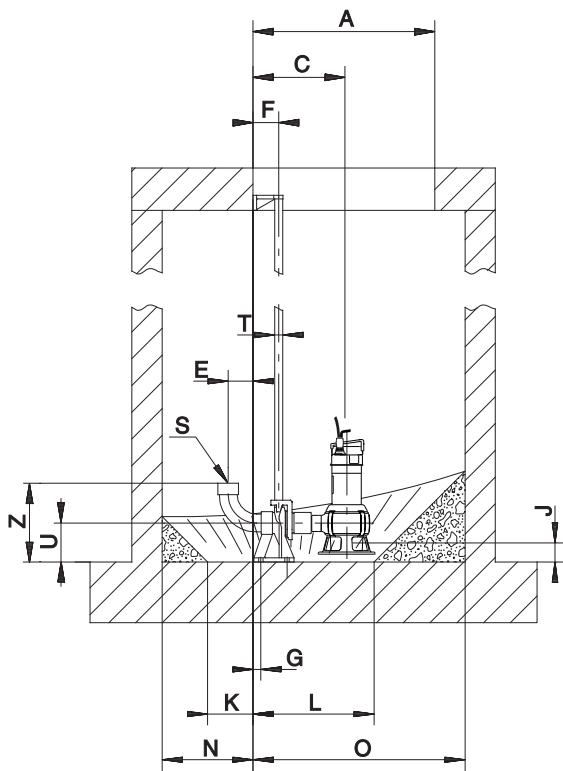

Fig. 26 Minimum well dimensions, Unilift AP35B

Pump type	Start [mm]	Stop [mm]
Unilift AP35B	633	270

Unilift AP35B installations



TM03 4194 1806

Fig. 27 Dimensional sketch, one-pump installation on auto-coupling system

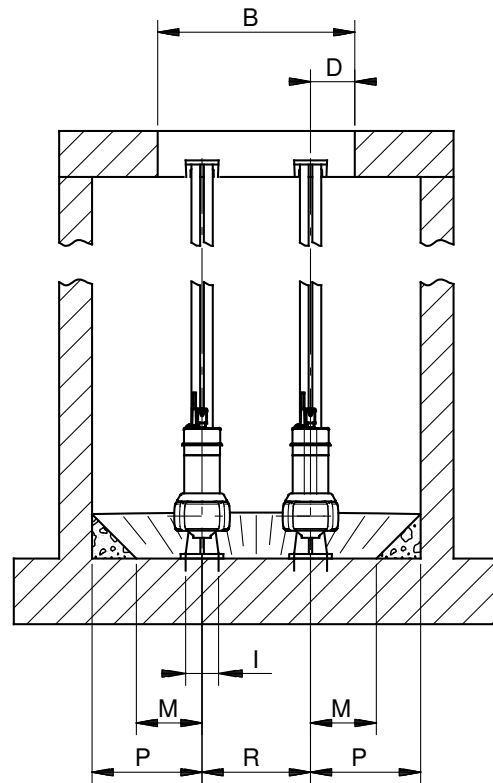

TM01 3592 0299

Fig. 28 Dimensional sketch, two-pump installation on auto-coupling system

One-pump installation on auto-coupling

Pump type	Dimensions [mm]																			
	A	B	C	D	E	F	G	I	J	K	L	M	N	O	P	R	S	T	U	Z
Unilift AP35B.50.06	Ø600	Ø600	304	135	82	85	65	100	76	150	400	200	300	700	500	-	R 2	¾"	130	261
Unilift AP35B.50.08	Ø600	Ø600	304	135	82	85	65	100	76	150	400	200	300	700	500	-	R 2	¾"	130	261

Two-pump installation on auto-coupling

Pump type	Dimensions [mm]																			
	A	B	C	D	E	F	G	I	J	K	L	M	N	O	P	R	S	T	U	Z
Unilift AP35B.50.06	600	600	304	135	82	85	26	100	76	150	400	200	300	700	335	330	R 2	¾"	130	261
Unilift AP35B.50.08	600	600	304	135	82	85	26	100	76	150	400	200	300	700	35	330	R 2	¾"	130	261

Unilift AP50



TM00 5740 1495

Fig. 29 Unilift AP50

The Unilift AP50 pump is a single-stage submersible pump designed for pumping effluent and sewage. The pump is suitable for these applications:

- groundwater lowering
- pumping in drainage collecting wells
- pumping in surface water collecting wells with inflow from roof gutters, shafts, tunnels, etc.
- emptying of ponds, tanks, etc.
- pumping of fibre-containing wastewater from laundries and industries
- pumping of domestic wastewater from septic tanks and sludge treating systems
- pumping of domestic wastewater with/without discharge from water closets.

Liquid temperature range: 0 °C to +55 °C.

Approvals

VDE, LGA, UL and CSA.

Automatic operation

The pump is available for automatic as well as manual operation and can be installed in a permanent installation or used as a portable pump. The pump is available in these versions:

- with float switch fitted for automatic on/off operation between two liquid levels (single-phase pumps)
- with separate level switch and control box for automatic on/off operation between two liquid levels (three-phase pumps)
- without level switch for manual on/off operation.

Pumps fitted with float switch can also be used for manual on/off operation. In this case, the float switch must be secured in an upward-pointing position.

Pump sleeve and housing

The stainless steel pump sleeve is made in one piece and equipped with an insulated carrying handle.

The suction strainer is clipped on to the pump housing and can easily be removed for maintenance. The strainer prevents the passage of large solids and ensures a slow flow into the pump.

The stainless steel pump housing is fitted with an internal riser pipe ensuring high efficiency. The riser pipe has a number of holes enabling efficient cooling of the motor during operation. The cable entry is of the socket and plug connection type, allowing for quick and easy dismantling.

Discharge port

All Unilift AP50 pumps have a threaded Rp 2 vertical discharge port.

Shaft and bearings

The stainless steel shaft rotates in maintenance-free prelubricated ball bearings.

Impeller

The stainless steel impeller is a vortex impeller with L-shaped blades and a clearance of 50 mm in the pump housing. The blades are curved backwards to reduce any harmful effect from solid particles and to minimise power consumption. The impeller has a protective cap to prevent the deposit of long-fibred material.

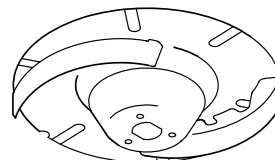

TM00 5477 0895

Fig. 30 Impeller, Unilift AP50

Shaft seal

The shaft seal is a combination of a mechanical, bellows shaft seal and a lip seal with 60 ml oil between. Seal faces are made of silicone carbide.

Motor

The motor is a single- or three-phase asynchronous dry-rotor motor.

Enclosure class: IP68
 Insulation class: F (155 °C)
 Cable type: H07RN-F.

Single-phase motors have built-in thermal protection.

Materials

Component	Material	DIN W.-Nr.	AISI
Pump housing	Stainless steel	1.4301	304
Riser pipe	Stainless steel	1.4301	304
Impeller	Stainless steel	1.4301	304
Pump sleeve	Stainless steel	1.4401	316
Pump shaft - wet end	Stainless steel	1.4301	304
Bearings	Heavy-duty prelubricated ball bearings		
O-rings	NBR rubber		
Screws	Stainless steel	1.4301	304
Cables	Neoprene		
Oil	Shell Ondina 15, non-toxic		

Selection

The overview below is suitable for the selection of the correct size of Unilift AP50 pumps used in stationary applications.

To ensure that the discharge pipe is self-cleaning, the calculation of the pipe lengths is based on these requirements:

- use steel pipes
- the minimum flow velocity through the vertical discharge pipe (2") must be 1 m/s
- the minimum flow velocity through the horizontal discharge pipe (2½") must be 0.7 m/s.

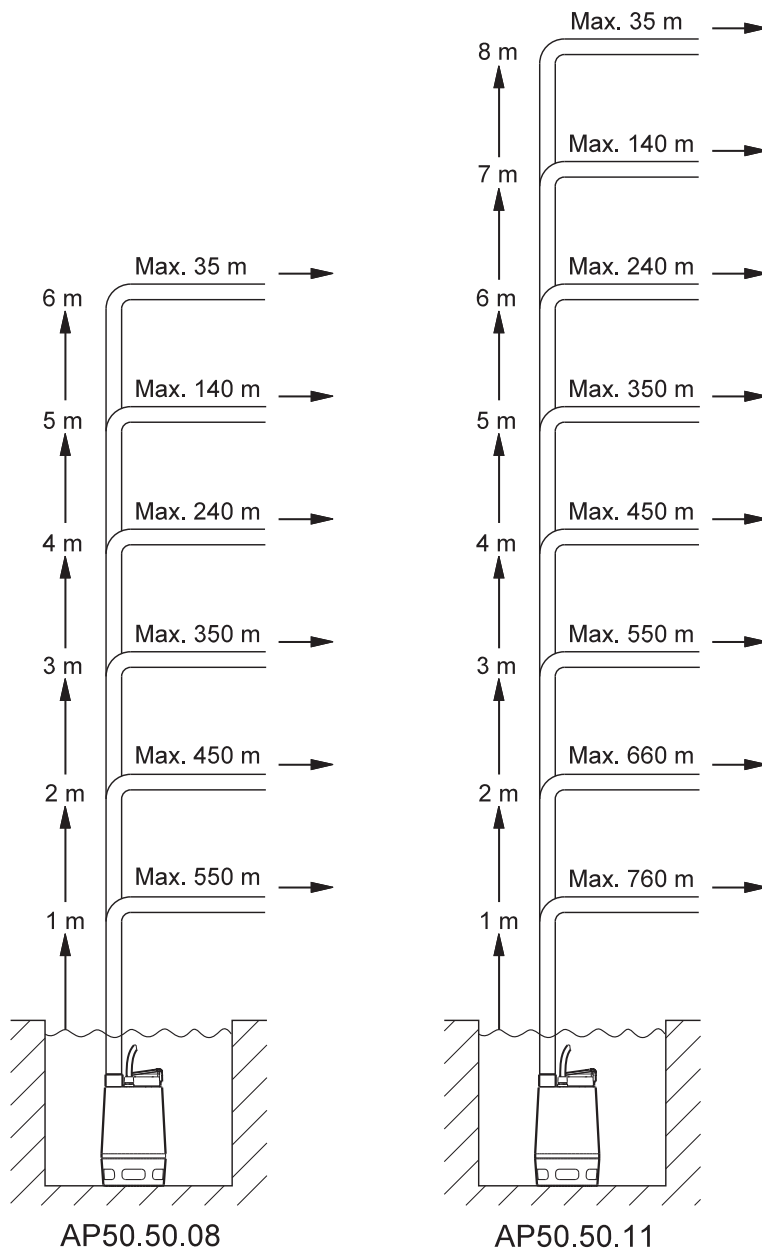

TM03 1880 3305

The overview is only intended as a guide. Grundfos is not liable for installations not complying with the overview.

Note: If the non-return valve is used, the pressure drop in the valve is 0.2 m head, which is to be subtracted from the vertical pipe lengths.

The vertical height of the discharge pipe should be measured from the pump stop level.

Performance curves

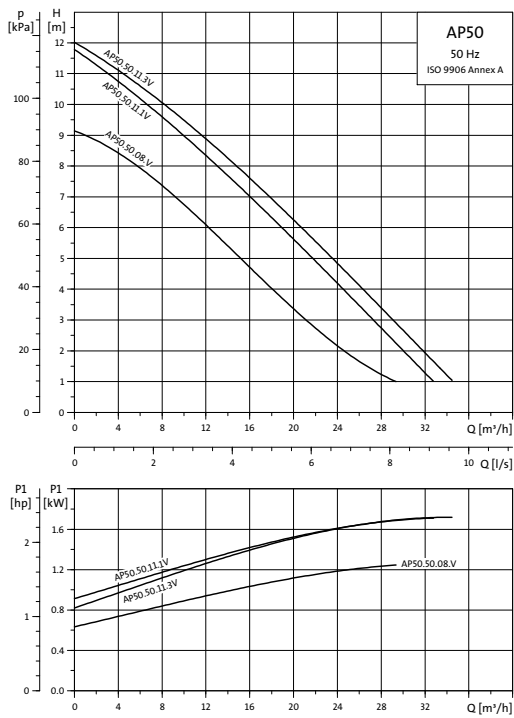

Dimensional sketch

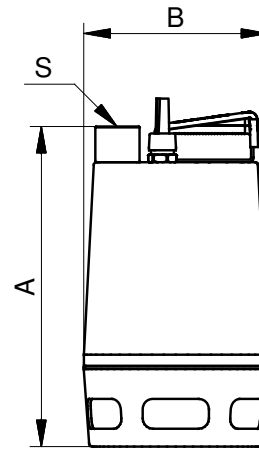

TM00 5524 0995

Fig. 31 Pump dimensions

Pump type	Voltage [V]	P ₁ [kW]	P ₂ [kW]	I _n [A]	Cos φ	I _{start} / I _n	Dimensions [mm]			Weight [kg]
							A	B	S	
Unilift AP50.50.08.1.V	1 x 230	1.3	0.8	5.9	0.99	1.9	436	241	Rp 2	15.1
Unilift AP50.50.08.A.1.V	1 x 230	1.3	0.8	5.9	0.99	1.9	436	241	Rp 2	15.1
Unilift AP50.50.08.3.V	3 x 230	1.2	0.8	3.3	0.85	2.8	436	241	Rp 2	14.2
Unilift AP50.50.08.A.3.V	3 x 230	1.2	0.8	3.3	0.85	2.8	436	241	Rp 2	16.5
Unilift AP50.50.08.3.V	3 x 400	1.2	0.8	2.0	0.80	3.0	436	241	Rp 2	14.2
Unilift AP50.50.08.A.3.V	3 x 400	1.2	0.8	2.0	0.80	3.0	436	241	Rp 2	16.5
Unilift AP50.50.11.1.V	1 x 230	1.6	1.1	8.0	0.92	4.0	436	241	Rp 2	15.1
Unilift AP50.50.11.A.1.V	1 x 230	1.6	1.1	8.0	0.92	4.0	436	241	Rp 2	15.1
Unilift AP50.50.11.3.V	3 x 230	1.6	1.2	6.0	0.85	2.8	436	241	Rp 2	15.6
Unilift AP50.50.11.A.3.V	3 x 230	1.6	1.2	6.0	0.85	2.8	436	241	Rp 2	17.9
Unilift AP50.50.11.3.V	3 x 400	1.9	1.2	3.0	0.88	4.9	436	241	Rp 2	15.6
Unilift AP50.50.11.A.3.V	3 x 400	1.9	1.2	3.0	0.88	4.9	436	241	Rp 2	17.9

Unilift AP50 installations

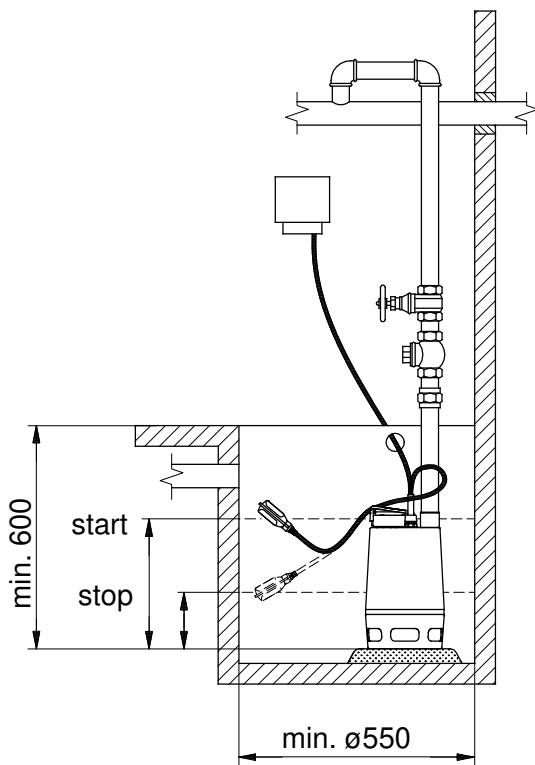

Fig. 32 One-pump installation with float switch

Adjustment of cable length for float switch

The difference in level between start and stop can be adjusted by changing the free cable length between the float switch and the pump handle.

- Increasing the free cable length results in fewer starts/stops and a large difference in level.
- Reducing the free cable length results in more starts/stops and a small difference in level.

In order for the float switch to start and stop the pump, the free cable length must be min. 100 mm and max. 350 mm.

Pump type	Cable length min. 100 mm		Cable length max. 350 mm	
	Start [mm]	Stop [mm]	Start [mm]	Stop [mm]
Unilift AP50	500	300	550	100

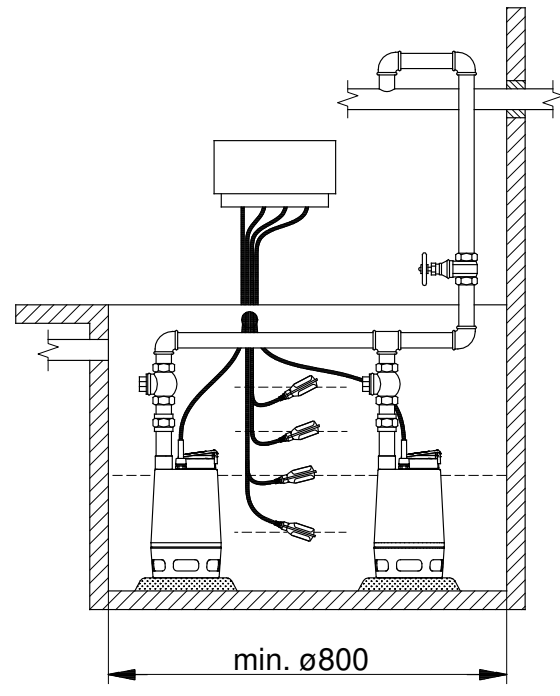

Fig. 33 Two-pump installation with four float switches

Two-pump installation

The Unilift AP pumps can be used for parallel installation together with a controller.

The example shows an installation with four float switches. The pumps are controlled by the liquid level in the tank.

When the liquid lifts up the second float switch from the bottom, the first pump will start.

If the liquid rises faster than one pump can manage, the third float switch from the bottom will be lifted up and start the second pump.

When the the bottom float switch is no longer lifted up by the liquid, the settable stop delay will set in and after that both pumps will be stopped.

When the top float switch is lifted up by the liquid, the high-level alarm will be activated.

Unilift AP50B



TM03 8260 0907

Fig. 34 Unilift AP50B

The Unilift AP50B pump is a single-stage submersible pump designed for pumping effluent.

The pump is suitable for these applications:

- groundwater lowering
- pumping in drainage collecting wells
- pumping in surface water collecting wells with inflow from roof gutters, shafts, tunnels, etc.
- emptying of ponds, tanks, etc.
- pumping of fibre-containing effluent from laundries and industries
- pumping of domestic effluent from septic tanks and sludge treating systems
- pumping of domestic effluent without discharge from water closets.

Liquid temperature range: 0 °C to +40 °C.

Automatic operation

The pump is available for automatic as well as manual operation and can be installed in a permanent installation or used as a portable pump. The pump is available in these versions:

- with float switch fitted for automatic on/off operation between two liquid levels (single-phase pumps)
- without level switch for manual on/off operation.

Pumps fitted with float switches can also be used for manual on/off operation. In this case, the float switch must be secured in an upward-pointing position.

Pump housing

Pump housing with an outstanding design for submersible wastewater pumps resulting in a high head.

The pump housing is made of a steel tube with a smooth surface and a hydraulically correct shape ensuring free passage of particles.

Ring stand, pump inlet and pump housing are fastened to the motor by means of four springs enabling quick and easy dismantling.

Discharge port

All Unilift AP50B pumps have a threaded R 2 horizontal discharge port.

Shaft and bearings

The stainless steel shaft rotates in maintenance-free prelubricated ball bearings.

Impeller

The stainless steel impeller is a vortex impeller with L-shaped blades and a clearance of 50 mm in the pump housing. The blades are curved backwards to reduce any harmful effect from solid particles and to minimise power consumption. The impeller has a protective cap to prevent the deposit of long-fibred material.

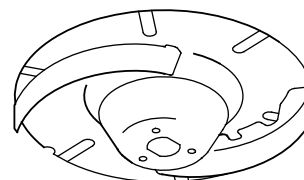

TM00 5477 0895

Fig. 35 Impeller, Unilift AP50B

Shaft seal

The shaft seal is a combination of a mechanical, bellows shaft seal and a lip seal with 80 ml oil between. Seal faces are made of silicone carbide.

Motor

The motor is a single- or three-phase asynchronous dry-rotor motor.

Enclosure class: IP68
 Insulation class: F (155 °C)
 Cable type: H07RN-F.

Single-phase motors have built-in thermal protection.

Materials

Component	Materials	DIN W.-Nr.	AISI
Pump housing	Stainless steel	1.4301	304
Impeller	Stainless steel	1.4301	304
Washer	Stainless steel	1.4301	304
Protective cap	Novolen 2360 Kx		
Motor unit complete	Parts in contact with liquid: Stainless steel	1.4401	316
Pump shaft	Stainless steel	1.4301	304
Motor cable	Neoprene		
O-rings	NBR rubber		
Spring	Stainless steel	1.4310	
Pump inlet	Stainless steel	1.4301	304
Ring stand	Polycarbonate		
Oil	Shell Ondina 15, non-toxic		

Selection

The overview below is suitable for the selection of the correct size of Unilift AP50B pumps used in stationary applications.

To ensure that the discharge pipe is self-cleaning, the calculation of the pipe lengths is based on these requirements:

- use steel pipes
- the minimum flow velocity through the vertical discharge pipe (2") must be 1 m/s
- the minimum flow velocity through the horizontal discharge pipe (2½") must be 0.7 m/s.

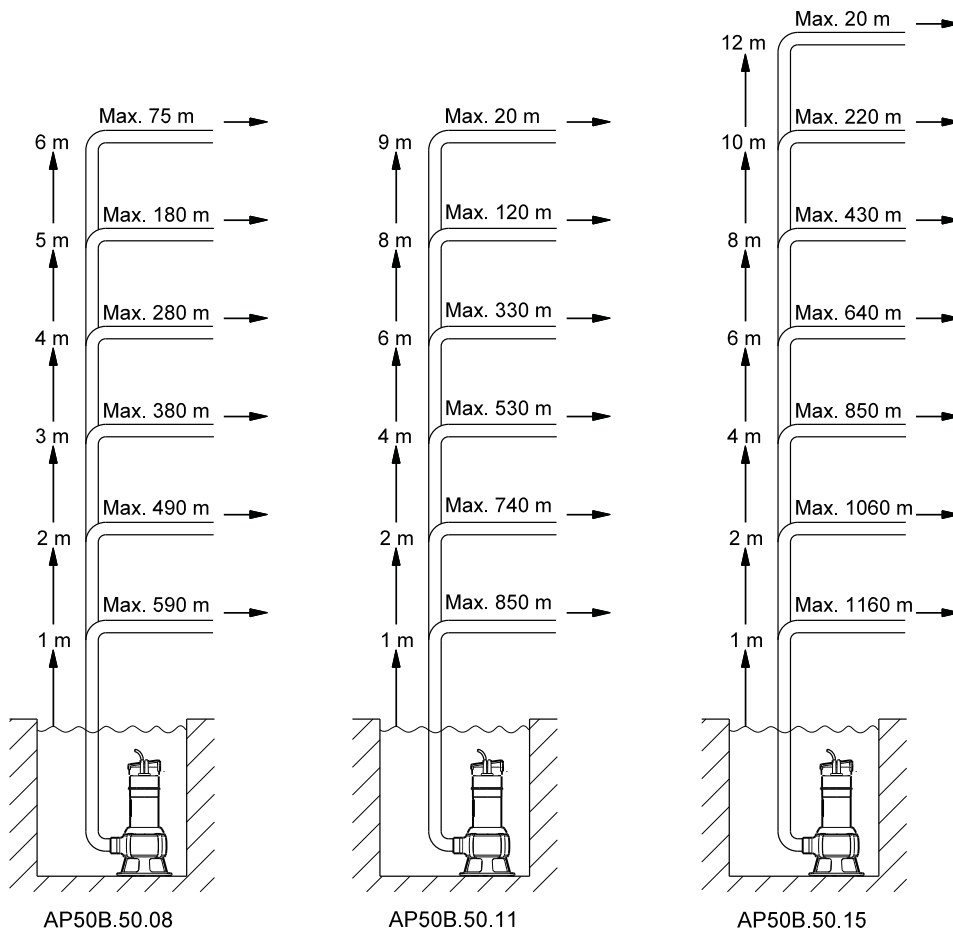

The overview is only intended as a guide. Grundfos is not liable for installations not complying with the overview.

The vertical height of the discharge pipe should be measured from the pump stop level.

TM03 1882 3305

Performance curves

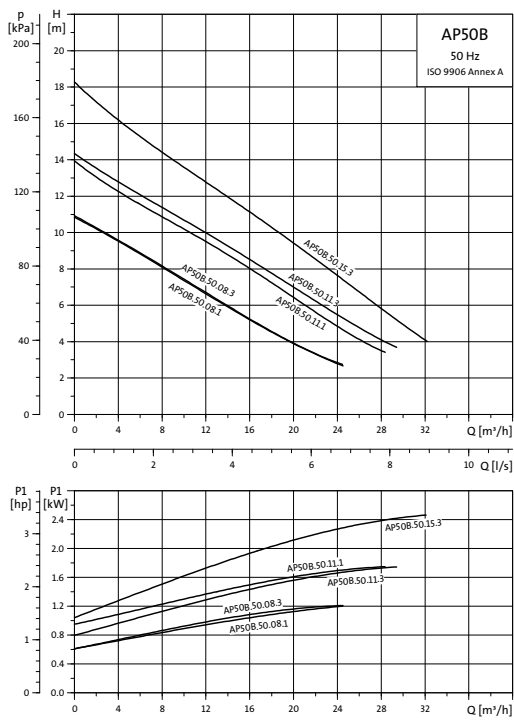

TM01 3582 0803

Dimensional sketch

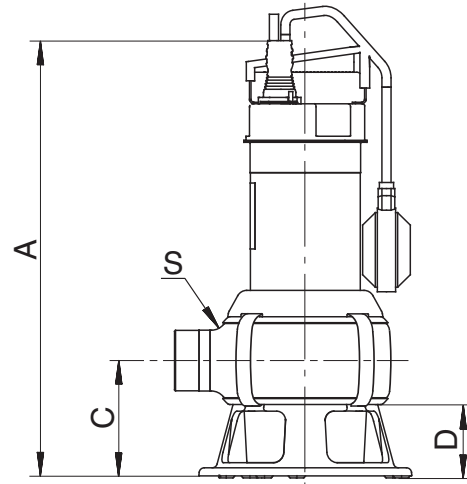

TM03 4097 1806

Fig. 36 Pump dimensions

Pump type	Voltage [V]	P ₁ [kW]	P ₂ [kW]	I _n [A]	Cos φ	C [μF]	I _{start} / I _n	Dimensions [mm]				Weight [kg]	Cable length and plug
								A	C	D	S		
Unilift AP50B.50.08.A1.V	1 x 230	1.2	0.7	5.37	0.97	16	18.4	468	116	73	R 2	10.1	5 m with Schuko plug
Unilift AP50B.50.08.1.V	1 x 230	1.2	0.7	5.37	0.97	16	18.4	468	116	73	R 2	10.1	10 m with Schuko plug
Unilift AP50B.50.08.3.V	3 x 400	1.25	0.8	1.95	0.89		10.6	468	116	73	R 2	8.4	5 m without plug
Unilift AP50B.50.11.A1.V	1 x 230	1.75	1.2	8.00	0.95	16	23.8	468	116	73	R 2	10.2	5 m with Schuko plug
Unilift AP50B.50.11.1.V	1 x 230	1.75	1.2	8.00	0.95	16	23.8	468	116	73	R 2	10.2	10 m with Schuko plug
Unilift AP50B.50.11.3.V	3 x 400	1.75	1.3	2.81	0.90		16.0	468	116	73	R 2	9.7	5 m without plug
Unilift AP50B.50.15.3.V	3 x 400	2.15	1.5	3.00	0.88		22.4	468	116	73	R 2	10.0	5 m without plug

Start/stop level

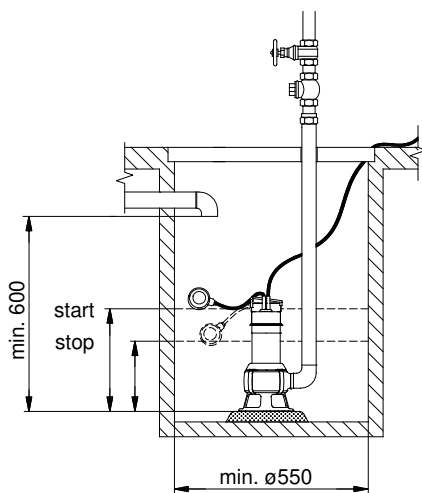

TM03 1914 3305

Fig. 37 Minimum well dimensions, Unilift AP50B

Pump type	Start [mm]	Stop [mm]
Unilift AP50B	633	270

Unilift AP50B installations

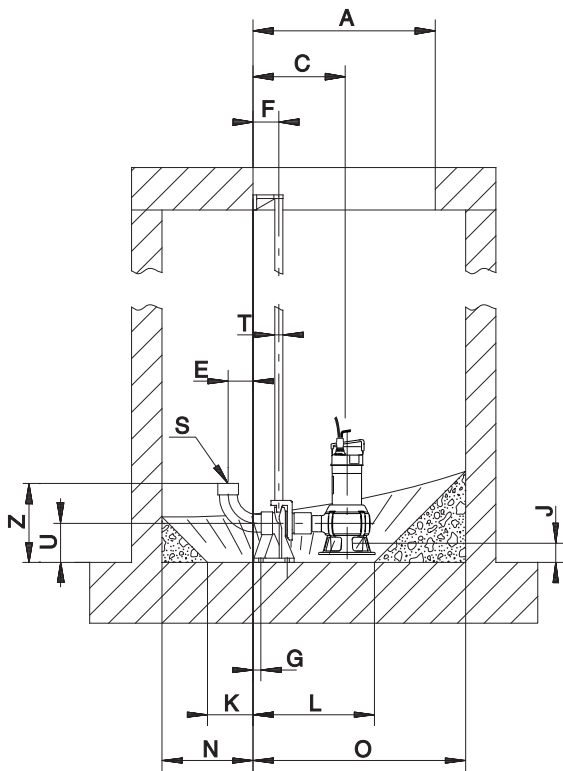

TM03 4194 1806

Fig. 38 Dimensional sketch, one-pump installation on auto-coupling system

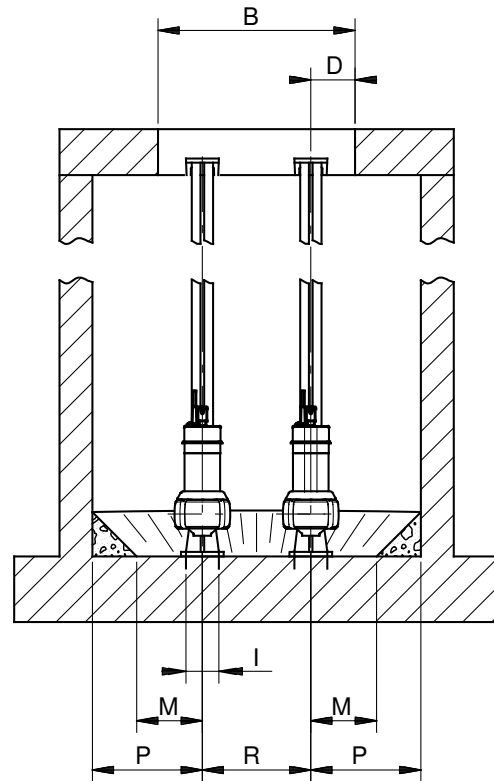

TM01 3592 0299

Fig. 39 Dimensional sketch, two-pump installation on auto-coupling system

One-pump installation on auto-coupling

Pump type	Dimensions [mm]																			
	A	B	C	D	E	F	G	I	J	K	L	M	N	O	P	R	S	T	U	Z
Unilift AP50B.50.08	Ø600	Ø600	304	135	82	85	65	100	76	150	400	200	300	700	500	-	R 2	¾"	130	261
Unilift AP50B.50.11	Ø600	Ø600	304	135	82	85	65	100	76	150	400	200	300	700	500	-	R 2	¾"	130	261
Unilift AP50B.50.15	Ø600	Ø600	304	135	82	85	65	100	76	150	400	200	300	700	500	-	R 2	¾"	130	261

Two-pump installation on auto-coupling

Pump type	Dimensions [mm]																			
	A	B	C	D	E	F	G	I	J	K	L	M	N	O	P	R	S	T	U	Z
Unilift AP50B.50.08	600	600	304	135	82	85	26	100	76	150	400	200	300	700	335	330	R 2	¾"	130	261
Unilift AP50B.50.11	600	600	304	135	82	85	26	100	76	150	400	200	300	700	335	330	R 2	¾"	130	261
Unilift AP50B.50.15	600	600	304	135	82	85	26	100	76	150	400	200	300	700	335	330	R 2	¾"	130	261

Control box

Variants

The Unilift AP pump range comprises versions with or without control box and float switch, designed for single-phase or three-phase power supply.

All types are designed for voltage tolerances of $\pm 10\%$.

Pumps with control box and float switch

Some Unilift AP pumps are available with float switch for automatic start/stop of the pump. The float switch cable should be fastened to the pump handle.

The difference in level between start and stop can be adjusted by changing the free cable length between the float switch and the pump handle.

Large difference in level: Long cable.

Small difference in level: Short cable.

The float switch is connected direct to the control box by a 10-metre cable.

The mains cable between the pump and the control box is 10 metres. The mains cable of the control box is a 0.8-metre free cable end.

The control box includes a motor starter. The pumps require no further motor protection.

In case of a too high level, an alarm signal can be given by a separate float switch connected to an alarm. High-level alarm switch and alarm are available as accessories.

For further details, see "Product range", from page 53.

Pumps with control box without float switch for manual on/off operation

The mains cable between the pump and the control box is 10 metres. The mains cable of the control box is a 0.8 metres long free cable end.

The control box includes a motor starter and a run capacitor but no relays for float switch.

Pumps without control box

Pumps without control box must be connected to a separate motor starter, available as an accessory.

Single-phase pumps must also be connected to a capacitor.

Level controller

A level controller and switches are available as accessories for the control, monitoring and protection of three-phase 50 Hz Unilift AP pumps.

The level controller incorporates motor starter, contactors and light-emitting diodes (LC/LCD) for indication of operating conditions.

Grundfos offers three types of level controller: LC, LCD 107, LC, LCD 108 and LC, LCD 110. The three level controllers are described in the following pages.

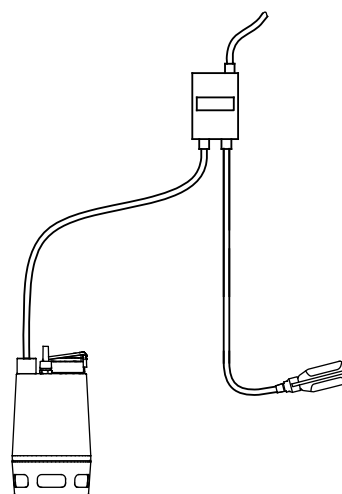

Fig. 40 Unilift AP35/50 pump with control box and float switch

TM03 1899 3305

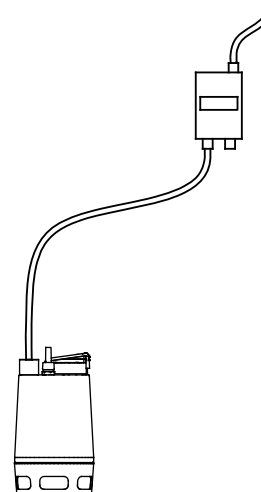
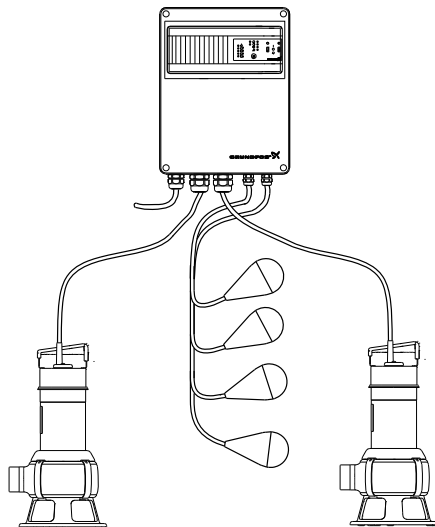

Fig. 41 Unilift AP35/50 pump with control box without float switch for manual on/off operation

TM03 1900 3305



TM03 1901 3305

Fig. 42 Unilift AP35B/AP50B pumps with LCD level controller

LC 107, LCD 107

The LC 107 and LCD 107 pump controllers are designed for level control, monitoring and protection of Grundfos Unilift AP pumping systems up to 23 A/11 kW (P_1) per pump starting direct-on-line.

- LC 107 is a one-pump controller
- LCD 107 is a two-pump controller.

LC 107 and LCD 107 are supplied as complete controllers incorporating motor protection relay, bell-shaped level pickups, pneumatic tubes and control unit.

Control is based on pneumatic signals which the LC 107 and LCD 107 receive via pneumatic tubes from two or three level pickups positioned in a collecting tank.

The LC 107 and LCD 107 enable the following:

- control of one or two pumps based on signals from bell-shaped level pickups
- automatic pump changeover (even distribution of operating hours on both pumps)
- selection of automatic test run every 24 hours during long periods of inactivity to prevent the shaft from seizing up
- protection against water hammer as quick restart/ simultaneous start is blocked and delayed
- battery back-up in case of mains supply failure (accessory!)
- starting delay within the range from 0 to 255 seconds (random) after returning from battery operation to mains operation (resulting in an even mains load when several pumping stations are started up at the same time)
- selection of automatic alarm resetting
- selection of automatic restarting
- setting of stop delays matching the actual operating conditions
- indication of liquid level
- alarm indication of:
 - too high liquid level which triggers a high-level alarm
 - overload (via motor protection relay)
 - overtemperature (via PTC resistance/thermal switch in motor)
 - wrong phase sequence
 - mains supply failure
 - failing level pickup.

As standard, the LC 107 and LCD 107 have two alarm signal outputs:

- common alarm
- high-level alarm.

LC 107

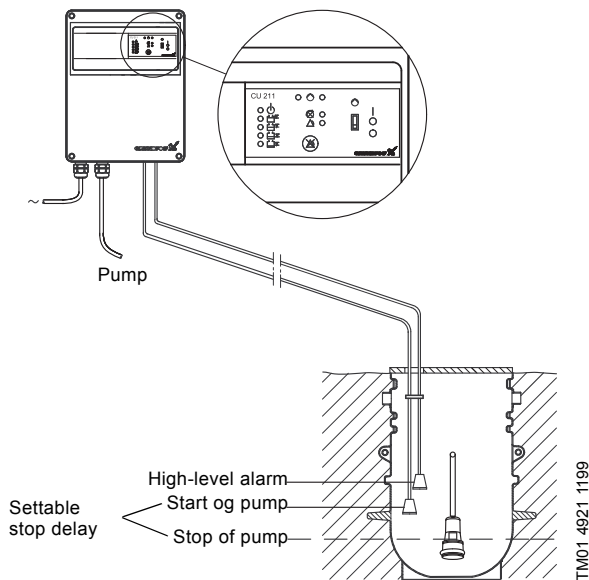

Fig. 43 Installation with LC 107 and two level pickups

LCD 107

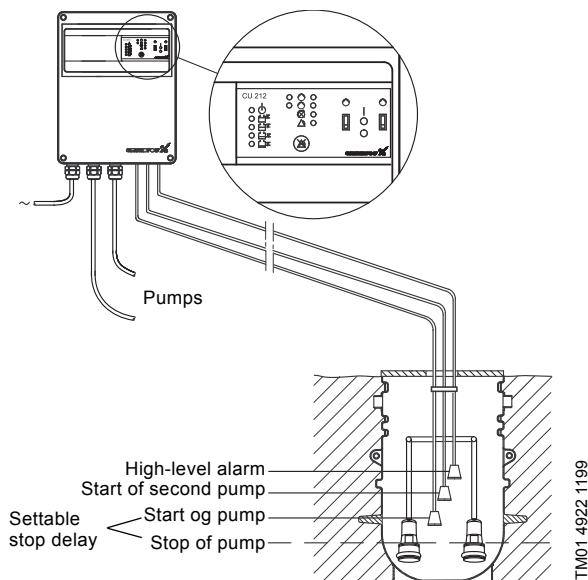

Fig. 44 Installation with LCD 107 and three level pickups

Technical data

Voltage tolerances

-15 %/+10 % of nominal voltage.

Mains frequency

50/60 Hz.

Ambient temperature

- During operation: -30 °C to +50 °C (must not be exposed to direct sunlight).
- In storage: -30 °C to +60 °C.

Enclosure class

IP55.

Pneumatic tubes

- Maximum 20 m per tube (standard: pneumatic tube of 10 metres).
- Diameter: 10 mm.
- Material: PA 11.

Outputs for alarm devices

Max. 230 VAC / max. 2 A / min. 10 mA / AC 1.

Dimensions

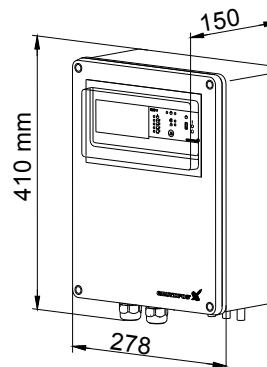

Fig. 45 Dimensional sketch, control cabinet

LC 108, LCD 108

The LC 108 and LCD 108 pump controllers are designed for level control, monitoring and protection of Grundfos Unilift AP pumps in wastewater, water supply and drainage systems.

Up to 23 A/11 kW (P_1) starting direct-on-line (DOL).

Up to 72 A/30 kW (P_1) starting star-delta (Y/D).

- LC 108 is a one-pump controller
- LCD 108 is a two-pump controller.

The LC 108 and LCD 108 are supplied as complete controllers incorporating motor protection relay and control unit.

The LC 108 and LCD 108 enable the following:

- control of one or two pumps based on signals from float switches, electrodes or flow switches
- selection of automatic test run (every 24 hours) during long periods of inactivity to prevent the shaft from seizing up
- protection against water hammer as quick restart is blocked and delayed (5 seconds)
- selection of automatic alarm resetting
- selection of automatic restarting (after overtemperature)
- setting of stop delays matching the actual operating conditions
- indication of liquid level
- alarm indication of:
 - wrong phase sequence
 - inadmissibly high liquid level
 - overload (via motor protection relay)
 - overtemperature (via PTC resistance or thermal switch in motor)
 - defective float switch, electrode or flow switch
 - dry running
 - mains supply failure (by installing a battery back-up, available as an accessory).
- automatic pump changeover (even distribution of operating hours on both pumps) (LCD 108 only).

As standard, the LC 108 and LCD 108 controllers incorporate a buzzer for alarm indication.

Furthermore, the controller has one alarm output for common alarm.

Applications

The LC 108 and LCD 108 can be connected and set to operation/control in seven different ways:

- systems with two float switches
- systems with three float switches
- systems with four float switches
- systems with two electrodes
- systems with three electrodes
- systems for filling applications
- systems for drainage applications.

Technical data

Voltage tolerances

–15 %/+10 % of nominal voltage.

Mains frequency

50/60 Hz.

Ambient temperature

- During operation: –30 °C to +50 °C (must not be exposed to direct sunlight).
- In stock: –30 °C to +60 °C.

Enclosure class

IP55.

Outputs for alarm devices

Max. 230 VAC / max. 2 A / min. 10 mA / AC 1.

Supply system earthing

For TN systems and TT systems.

Rated insulation voltage, U_i

4 kV.

Rated impulse withstand voltage, U_{imp}

4 kV.

EMC (electromagnetic compatibility)

According to EN 50 081-1 and EN 50 082-2.

Dimensions

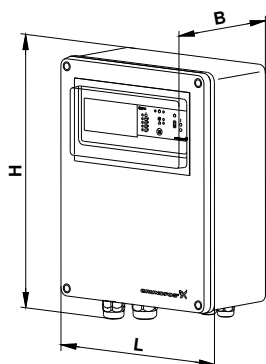

TM01 9007 0900

Fig. 46 Dimensional sketch, control cabinet

Type	Dimensions [mm]		
	H	L	B
LC 108, direct-on-line	410	278	150
LCD 108, direct-on-line			
LC 108, star-delta	628	445	180

Float switches

The Unilift AP pumps in combination with LC 108 or LCD 108 are available with float switches for automatic level control. Float switches supplied by Grundfos are of the non-mercury type.

LC 108 can be fitted with up to three float switches:

- Min.: Stops the pump.
- Max.: Starts the pump.
- Alarm: Alarm (optional): high-water level or pump fault.

LCD 108 can be fitted with up to four float switches:

- Min.: Stops both pumps.
- Max. 1: Starts one pump.
- Max. 2: Starts the other pump.
- Alarm: Alarm (optional): high-water level or pump fault.

The float switches are to be installed in the collecting tank floating on the pumped liquid.

The position of the float switches decides when the LC 108 or LCD 108 starts and stops the Unilift AP pumps:

- When the float switch is pointing upwards, the float switch contact will be closed and the pump will start.
- When the float switch is pointing downwards, the float switch contact will be opened and the pump will stop.

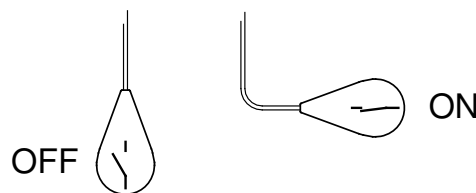

TM00 6678 4695

Fig. 47 Principle sketch of float switch contact

LC 110, LCD 110

The LC 110 and LCD 110 pump controllers are designed for level control, monitoring and protection of Grundfos Unilift AP pumps in wastewater, water supply and drainage systems up to 23 A/11 kW (P_1) starting direct-on-line (DOL).

The LC 110 and LCD 110 are supplied as complete controllers incorporating motor protection relay and control unit.

The LC 110 and LCD 110 enable the following:

- control of one or two pumps based on signals from electrodes
- selection of automatic test run (every 24 hours) during long periods of inactivity to prevent the shaft from seizing up
- starting delay within the range from 0 to 255 seconds (random) after returning from battery operation to mains operation (resulting in an even mains load when several pumping stations are started up at the same time)
- protection against water hammer as quick restart is blocked and delayed (5 seconds)
- selection of automatic alarm resetting
- selection of automatic restarting (after overtemperature)
- setting of stop delays matching the actual operating conditions
- indication of liquid level
- alarm indication of:
 - wrong phase sequence
 - high liquid level
 - overload (via motor protection relay)
 - overtemperature (via thermal switch in motor)
 - dry running
 - mains supply failure (when battery back-up is fitted as an accessory).

As standard, the LC 110 and LCD 110 controllers incorporate a buzzer for indication of alarm.

Furthermore, the controller has one alarm output for common alarm.

Applications

The LC 110 and LCD 110 can be connected and set to operation/control in six different ways:

- systems with three electrodes (LC 110):
Electrode for reference, start/stop and high-level alarm
- systems with four electrodes (LC 110):
Electrode for reference, stop, start and high-level alarm

- systems with five electrodes (LC 110):
Electrode for reference, dry-running alarm, stop, start and high-level alarm
- systems with four electrodes (LCD 110):
Electrode for reference, start of pump 1/common stop, start of pump 2 and high-level alarm
- systems with five electrodes, parallel operation (LCD 110):
Electrode for reference, common stop, start of pump 1, start of pump 2 and high-level alarm
- systems with five electrodes, 100 % standby (LCD 110):
Electrode for reference, common stop, start of pump 1, high-level alarm and start of pump 2
- systems with five electrodes, full control (LCD 110):
Electrode for reference, stop of pump 1, stop of pump 2, start of pump 1 and start of pump 2.

Technical data

Voltage tolerances

–15 %/+10 % of nominal voltage.

Mains frequency

50/60 Hz.

Ambient temperature

- During operation: –30 °C to +50 °C (must not be exposed to direct sunlight).
- In stock: –30 °C to +60 °C.

Enclosure class

IP55.

Outputs for alarm devices

Max. 230 VAC / max. 2 A / min. 10 mA / AC 1.

Supply system earthing

For TN systems and TT systems.

Rated insulation voltage, U_i

4 kV.

Rated impulse withstand voltage, U_{imp}

4 kV.

EMC (electromagnetic compatibility)

According to EN 50 081-1 and EN 50 082-2.

Dimensions

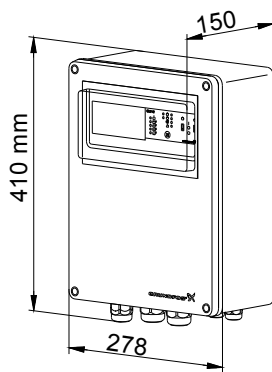

TM01 8152 5099

Fig. 48 Dimensional sketch, control cabinet

Accessories for Unilift CC, KP, AP pumps

Pos.	Accessories		Pump type						Product number
			Unilift						
			CC	KP	AP 12.40	AP 12.50	AP 35	AP 35B	
1	Bushing for pipe connection(PVC)	Rp 1½/2			●	●			96023831
		Rp 2/2½			●			●	96023832
2	Hose nipple(PVC)	Rp 1½/1½			●	●			96003997
		Rp 1½/2			●	●			96023834
		Rp 2/2			●	●	●	●	96023835
		Rp 2/2½			●	●		●	96023836
3	10 m rubber hose incl. clamps(PVC)	1½"			●	●			96023837
		2"			●	●	●	●	96023838
		2½"			●			●	96023839
4	Connecting piece for rubber hoses(PVC)	Rp 1½			●	●			96023840
		Rp 2			●	●	●	●	96023841
		Rp 2½			●			●	96023842
5	Non-return valve,(PVC) ball type	Rp 1½			●	●			96023843
		Rp 2			●	●	●	●	96023844
		Rp 2½ ★			●			●	96002003
6	Isolating valve(PVC)	Rp 1½			●	●			96023846
		Rp 2			●	●	●	●	96023847
		Rp 2½			●			●	96023848
7	Hexagon nipple(PVC)	Rp 1½			●	●			96023849
		Rp 2			●	●	●	●	96023850
		Rp 2½			●			●	96023851
8	Union(PVC)	Rp 1½			●	●			96023852
		Rp 2			●	●	●	●	96023853
		Rp 2½			●			●	96023854
9	90 ° pipe bend(PVC)	Rp 1½			●	●			96023855
		Rp 2			●	●	●	●	96023856
		Rp 2½			●			●	96023857
10	Non-return valve for location in the pump discharge (stainless steel)	Rp 1¼	●	●					00015220
		Rp 1½			●	●			96003855
	Auto-coupling	Rp 2/Rp 2					●	●	96429519
	Hose couplings	G 1¼ x Ø25			●				00ID3588
	Screwed couplings(polyamide)	G 1¼ x Ø32			●				00ID3589
		G 1¼ x Ø40			●				00ID3590

★ Cast iron

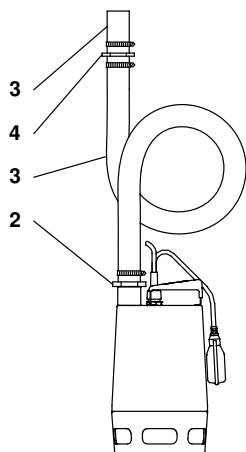

Fig. 49 Unilift with hose connection

TM00 5924 1895

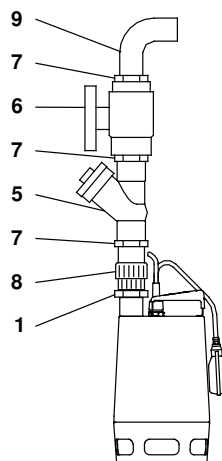

Fig. 50 Unilift with pipe connection, isolating valve and non-return valve

TM00 5925 1895

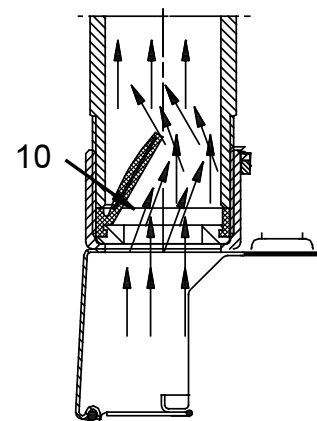

Fig. 51 Functional sketch of non-return valve in Unilift pump discharge

TM01 8708 0700

Level controllers and accessories

Description	Operating current per pump [A]	Mains switch required [A]	Language of Installation and operating instructions	Grundfos product no.	Grundfos product no. including hour counter	Grundfos product no. including start counter	Grundfos product no. including combined hour and start counter
LC 107 level controller for one pump 1 x 230 V, direct-on-line starting	1.0 - 5.0	16	GB/DK/D/F/NL	96841806			
	3.2 - 12.0	16	GB/DK/D/F/NL	96841807			
LC 107 level controller for one pump 3 x 400 V, direct-on-line starting	1 - 5.0	16	GB/DK/D/F/NL	96841832			
	3.2 - 12.0	16	GB/DK/D/F/NL	96841834			
LCD 107 level controller for two pumps 1 x 230 V, direct-on-line starting	1.0 - 5.0	16	GB/DK/D/F/NL	96841836			
	3.2 - 12.0	25	GB/DK/D/F/NL	96841837			
LCD 107 level controller for two pumps 3 x 400 V, direct-on-line starting	1 - 5.0	16	GB/DK/D/F/NL	96841841			
	3.2 - 12.0	25	GB/DK/D/F/NL	96841842			
	6.0 - 23.0	50	GB/DK/D/F/NL	96841843			
	1.0 - 5.0	16	GB/D/PL/NL	96841844	96841845		96841846
GB/GR/I/F/E			96841873	96841874		96841875	
LC 108 level controller for one pump 1 x 230 V, direct-on-line starting	3.2 - 12.0	16	GB/DK/S/RU	96841902	96841903		96841904
			GB/D/PL/NL	96841847	96841848	96841849	96841850
			GB/GR/I/F/E	96841876	96841877	96841878	96841879
			GB/DK/S/RU	96841905	96841906	96841907	96841908
	6.0 - 23.0	35	GB/D/PL/NL	96841854			
			GB/GR/I/F/E	96841883			
			GB/DK/S/RU	96841912			
			GB/D/PL/NL	96841855			
LC 108 level controller for one pump 3 x 230 V, direct-on-line starting	1 - 5.0	16	GB/GR/I/F/E	96841884			
			GB/DK/S/RU	96841913			
	3.2 - 12.0	16	GB/D/PL/NL	96841856			96841857
			GB/GR/I/F/E	96841885			96841886
			GB/DK/S/RU	96841914			96841915
			GB/D/PL/NL	96841858			
	6.0 - 23.0	16	GB/GR/I/F/E	96841887			
			GB/DK/S/RU	96841916			
	1.0 - 5.0	16	GB/D/PL/NL	96841859	96841860		96841861
			GB/GR/I/F/E	96841888	96841889		96841890
LC 108 level controller for one pump 3 x 400 V, direct-on-line starting	3.2 - 12.0	16	GB/DK/S/RU	96841917	96841918		96841919
			GB/D/PL/NL	96841863	96841865	96841864	96841866
			GB/GR/I/F/E	96841892	96841894	96841893	96841895
			GB/DK/S/RU	96841921	96841923	96841922	96841924
	6.0 - 23.0	25	GB/D/PL/NL	96841867			96841868
			GB/GR/I/F/E	96841896			96841897
			GB/DK/S/RU	96841925			96841926
			GB/D/PL/NL	96841869			
	5.5 - 20.0	35	GB/GR/I/F/E	96841898			
			GB/DK/S/RU	96841927			
LC 108 level controller for one pump 3 x 400 V, star-delta starting	10.0 - 30.0	63	GB/D/PL/NL	96841870			
			GB/GR/I/F/E	96841899			
			GB/DK/S/RU	96841928			
			GB/D/PL/NL	96841871			
	15.5 - 59.0	125	GB/GR/I/F/E	96841900			
			GB/DK/S/RU	96841929			
	15.5 - 72.0	160	GB/D/PL/NL	96841872			
			GB/GR/I/F/E	96841901			
			GB/DK/S/RU	96841930			

Description	Operating current per pump [A]	Mains switch required [A]	Language of Installation and operating instructions	Grundfos product no.	Grundfos product no. including hour counter	Grundfos product no. including start counter	Grundfos product no. including combined hour and start counter
LCD 108 level controller for two pumps 3 x 230 V, direct-on-line starting	1 - 5.0	16	GB/D/PL/NL	96841935	96841936		96841937
			GB/GR/I/F/E	96841962	96841963	96841964	
			GB/DK/S/RU	96841989	96841990	96841991	
	3.2 - 12.0	25	GB/D/PL/NL	96841938	96841939		
			GB/GR/I/F/E	96841965	96841966		
			GB/DK/S/RU	96841992	96841993		
	6.0 - 23.0	50	GB/D/PL/NL	96841940	96841941		
			GB/GR/I/F/E	96841967	96841968		
			GB/DK/S/RU	96841994	96841995		
LCD 108 level controller for two pumps 3 x 400 V, direct-on-line starting	1 - 5.0	25	GB/D/PL/NL	96841942	96841943	96841944	96841945
			GB/GR/I/F/E	96841969	96841970	96841971	96841972
			GB/DK/S/RU	96841996	96841997	96841998	96841999
	3.2 - 12.0	40	GB/D/PL/NL	96841948	96841949		96841950
			GB/GR/I/F/E	96841975	96841976		96841977
			GB/DK/S/RU	96842002	96842003		96842004
	6.0 - 23.0	60	GB/D/PL/NL	96841951	96841952		96841953
			GB/GR/I/F/E	96841978	96841979		96841980
			GB/DK/S/RU	96842005	96842006		96842007
LCD 108 level controller for two pumps 3 x 400 V, star-delta starting	5.5 - 20.0	50	GB/D/PL/NL	96841954			
			GB/GR/I/F/E	96841981			
			GB/DK/S/RU	96842008			
	10.0 - 30.0	63	GB/D/PL/NL	96841955			
			GB/GR/I/F/E	96841982			
			GB/DK/S/RU	96842009			
	15.5 - 59.0	125	GB/D/PL/NL	96841956			
			GB/GR/I/F/E	96841983			
			GB/DK/S/RU	96842010			
15.5 - 72.0	160	GB/D/PL/NL	96841957				
		GB/GR/I/F/E	96841984				
		GB/DK/S/RU	96842011				
LC 110 level controller for one pump 1 x 230 V, direct-on-line	1 - 5.0	16	GB/DK/D	96842054			
	3.2 - 12.0	16	GB/DK/D	96842056			
	6.0 - 23.0	25	GB/DK/D	96842060			
LC 110 level controller for one pump 3 x 400 V, direct-on-line	1 - 5.0	16	GB/DK/D	96842061			
	3.2 - 12.0	16	GB/DK/D	96842064			
	6.0 - 23.0	25	GB/DK/D	96842066			
LCD 110 level controller for two pumps 1 x 230 V, direct-on-line	1 - 5.0	16	GB/DK/D	96842067			
	3.2 - 12.0	25	GB/DK/D	96842069			
LCD 110 level controller for two pumps 3 x 400 V, direct-on-line	1 - 5.0	16	GB/DK/D	96842080			
	3.2 - 12.0	25	GB/DK/D	96842087			
	6.0 - 23.0	50	GB/DK/D	96842094			

Accessories for controllers

Description	Product no.
Battery back-up	96002520
Flashing light for external alarm indication	62500020
Alarm horn for external alarm indication (outdoor installation)	62500021
Alarm horn for external alarm indication (indoor installation)	62500022
Hour counter [230 V]	96002514
Hour counter [400 V]	96002515
Start counter [230 V]	96002516
Start counter [400 V]	96002517
Combined hour and start counter [230 V]	96002518
Combined hour and start counter [400 V]	96002519
25 [A] external mains switch for supply cable	96002511
40 [A] external mains switch for supply cable	96002512
80 [A] external mains switch for supply cable	96002513
Bracket for electrodes	91713196
Three electrodes with 10 m cable	96076489
Four electrodes with 10 m cable	91713437

SMS module

The LC, LCD controllers can be equipped with an SMS module. An SMS module integrated in an LC, LCD controller acts as a time recorder for the pumps. When it has been programmed (using an ordinary mobile phone with text messaging facility), it can send text messages containing "high-water alarm", "general alarm", information about operating hours and the number of starts.

The SMS module is available with battery enabling it to send text messages that will inform you of power failure and when power has been restored.

The LC, LCD controller functions independently - both before and after integration of the SMS module. The SMS module is primarily intended as a monitoring unit or alarm transmitter. Thus, the operator will receive a text message in the event of an emergency mode in the system and will be able to retrieve operating information.

SMS module (GB*)	96805159
SMS module (DK*)	96805158
SMS module (D*)	96805160
SMS module (F*)	96805161
SMS module (ES*)	96805172
SMS module (RU*)	96805173
Antenna for SMS module	96805155
Battery for SMS module	96805157
SMS module kit complete (GB*)	96805179
SMS module kit complete (DK*)	96805177
SMS module kit complete (D*)	96805182
SMS module kit complete (F*)	96805183
SMS module kit complete (ES*)	96805184
SMS module kit complete (RU*)	96805185

* Language of text messages and installation and operating instructions.

Unilift CC

1 x 220 - 240 V

Pump type	Product number	Plug type			Float switch		Cable type		Net weight [kg]
		Schuko	Australia	Without plug	Without float switch	With float switch	H05RN-F 3G0.75	H07RN-F 3G1	
Unilift CC 5	96280965	●			●		●		4.35
	96280966	●				●	●		
	96280971		●		●		●		
	96280972		●			●	●		
	96280977			●	●		●		
	96280978			●		●	●		
Unilift CC 7	96280967	●			●			●	4.6
	96280968	●				●		●	
	96280973		●		●			●	
	96280974		●			●		●	
	96280979			●	●			●	
	96280980			●		●		●	
Unilift CC 9	96280969	●			●			●	6.5
	96280970	●				●		●	
	96280975		●		●			●	
	96280976		●			●		●	
	96280981			●	●			●	
	96280982			●		●		●	

Unilift KP 150

1 x 220 - 230 V

Pump type	Float switch	Vertical level switch	3 m cable	10 m cable	With plug	Plug type	Product no.
Unilift KP 150					●	Schuko	011H1300
Unilift KP 150	●		●		●	Schuko	011H1600
Unilift KP 150		●	●		●	Schuko	011H1400
Unilift KP 150	●			●	●	Schuko	011H1800
Unilift KP 150		●		●	●	Schuko	011H1900
Unilift KP 150				●	●	Denmark	011H2300
Unilift KP 150	●		●		●	Denmark	011H2600
Unilift KP 150		●	●		●	Denmark	011H2400
Unilift KP 150	●			●	●	Denmark	011H2800
Unilift KP 150		●		●	●	Denmark	011H2900
Unilift KP 150				●	●	Switzerland	011H3300
Unilift KP 150	●		●		●	Switzerland	011H3600
Unilift KP 150		●	●		●	Switzerland	011H3400
Unilift KP 150	●			●	●	Switzerland	011H3800
Unilift KP 150		●		●	●	Switzerland	011H3900
Unilift KP 150				●	●	Italy	011H5300
Unilift KP 150	●		●		●	Italy	011H5600
Unilift KP 150		●	●		●	Italy	011H5400
Unilift KP 150				●	●	Italy	011H5800
Unilift KP 150				●			011H6300
Unilift KP 150	●		●				011H6600
Unilift KP 150		●	●				011H6400
Unilift KP 150	●						011H6800
Unilift KP 150		●		●			011H6900

1 x 230 - 240 V

Pump type	Float switch	Vertical level switch	5 m cable	With plug	Plug type	Product no.
Unilift KP 150			●	●	Australia	01 1K 41 00
Unilift KP 150	●		●	●	Australia	01 1K 47 00
Unilift KP 150		●	●	●	Australia	01 1K 45 00

Unilift KP 250

1 x 220 - 230 V

Pump type	Float switch	Vertical level switch	3 m cable	10 m cable	With plug	Plug type	Product no.
Unilift KP 250				•	•	Schuko	012H1300
Unilift KP 250	•		•		•	Schuko	012H1600
Unilift KP 250		•	•		•	Schuko	012H1400
Unilift KP 250	•			•	•	Schuko	012H1800
Unilift KP 250		•		•	•	Schuko	012H1900
Unilift KP 250				•	•	Denmark	012H2300
Unilift KP 250	•		•		•	Denmark	012H2600
Unilift KP 250		•	•		•	Denmark	012H2400
Unilift KP 250	•			•	•	Denmark	012H2800
Unilift KP 250		•		•	•	Denmark	012H2900
Unilift KP 250				•	•	Switzerland	012H3300
Unilift KP 250	•		•		•	Switzerland	012H3600
Unilift KP 250		•	•		•	Switzerland	012H3400
Unilift KP 250	•			•	•	Switzerland	012H3800
Unilift KP 250		•		•	•	Switzerland	012H3900
Unilift KP 250				•	•	Italy	012H5300
Unilift KP 250	•		•		•	Italy	012H5600
Unilift KP 250		•	•		•	Italy	012H5400
Unilift KP 250	•			•	•	Italy	012H5800
Unilift KP 250				•			012H6300
Unilift KP 250	•		•				012H6600
Unilift KP 250		•	•				012H6400
Unilift KP 250	•			•			012H6800
Unilift KP 250		•					012H6900

1 x 230 - 240 V

Pump type	Float switch	Vertical level switch	5 m cable	With plug	Plug type	Product no.
Unilift KP 250			•	•	Australia	012K4100
Unilift KP 250	•		•	•	Australia	012K4700
Unilift KP 250		•	•	•	Australia	012K4500

3 x 380 - 415 V

Pump type	5 m cable	10 m cable	Product no.
Unilift KP 250	•		012M6100
Unilift KP 250		•	012M6300
Unilift KP 250	•		012M9100
Unilift KP 250		•	012M9300

Unilift KP 350

1 x 220 - 240 V

Pump type	Float switch	Vertical level switch	3 m cable	5 m cable	10 m cable	With plug	Plug type	Product no.
Unilift KP 350					•	•	Schuko	013N1300
Unilift KP 350	•		•			•	Schuko	013N1600
Unilift KP 350		•	•			•	Schuko	013N1400
Unilift KP 350	•				•	•	Schuko	013N1800
Unilift KP 350		•			•	•	Schuko	013N1900
Unilift KP 350					•	•	Denmark	013N2300
Unilift KP 350	•		•			•	Denmark	013N2600
Unilift KP 350		•	•			•	Denmark	013N2400
Unilift KP 350	•				•	•	Denmark	013N2800
Unilift KP 350		•			•	•	Denmark	013N2900
Unilift KP 350		•			•	•	Switzerland	013N3300
Unilift KP 350		•	•			•	Switzerland	013N3400
Unilift KP 350	•		•			•	Switzerland	013N3600
Unilift KP 350	•				•	•	Switzerland	013N3800
Unilift KP 350		•			•	•	Switzerland	013N3900
Unilift KP 350					•			013N6300
Unilift KP 350	•		•					013N6600
Unilift KP 350		•	•					013N6400
Unilift KP 350	•				•			013N6800
Unilift KP 350					•			013N6900
Unilift KP 350				•		•	Australia	013N4100
Unilift KP 350	•			•		•	Australia	013N4700
Unilift KP 350		•		•		•	Australia	013N4500

3 x 380 - 415 V

Pump type	5 m cable	10 m cable	Product no.
Unilift KP 350	•		013M6100
Unilift KP 350		•	013M6300
Unilift KP 350	•		013M9100
Unilift KP 350		•	013M9300

Unilift AP12

Pump type	Voltage [V]	Control box with 0.8 m supply cable	Float switch	10 m cable	3 m cable	With plug	Product no.
Unilift AP12.40.04.1	1 x 230			●		●	96011016
Unilift AP12.40.04.1	1 x 230			●			96011014
Unilift AP12.40.04.A.1	1 x 230		●		●	●	96011017
Unilift AP12.40.04.A.1	1 x 230		●		●		96011015
Unilift AP12.40.04.A.1	1 x 230		●	●		●	96011018
Unilift AP12.40.04.3	3 x 400			●			96011024
Unilift AP12.40.04.3	3 x 400			●		●	96023925
Unilift AP12.40.04.3	3 x 230			●			96011030
Unilift AP12.40.04.3	3 x 200			●			96011021
Unilift AP12.40.04.A.3	3 x 400	●	●	●			96011025
Unilift AP12.40.04.A.3	3 x 400	●	●	●		●	96023871
Unilift AP12.40.04.A.3	3 x 230	●	●	●			96011031
Unilift AP12.40.04.A.3	3 x 200	●	●	●			96011039
Unilift AP12.40.06.1	1 x 230			●		●	96001720
Unilift AP12.40.06.1	1 x 230			●			96001732
Unilift AP12.40.06.A.1	1 x 230		●		●	●	96001735
Unilift AP12.40.06.A.1	1 x 230		●	●		●	96010979
Unilift AP12.40.06.A.1	1 x 230		●		●		96001747
Unilift AP12.40.06.3	3 x 400			●			96001652
Unilift AP12.40.06.3	3 x 230			●			96010628
Unilift AP12.40.06.3	3 x 200			●			96010881
Unilift AP12.40.06.A.3	3 x 400	●	●	●			96010923
Unilift AP12.40.06.A.3	3 x 400	●	●	●		●	96023872
Unilift AP12.40.06.A.3	3 x 230	●	●	●			96010957
Unilift AP12.40.06.A.3	3 x 200	●	●	●			96010922
Unilift AP12.40.08.1	1 x 230			●			96001873
Unilift AP12.40.08.1	1 x 230			●		●	96001869
Unilift AP12.40.08.A.1	1 x 230		●		●	●	96001798
Unilift AP12.40.08.A.1	1 x 230		●	●		●	96010980
Unilift AP12.04.08.A.1	1 x 230		●		●		96001867
Unilift AP12.40.08.3	3 x 400			●			96001791
Unilift AP12.40.08.3	3 x 230			●			96010630
Unilift AP12.40.08.3	3 x 200			●			96010882
Unilift AP12.40.08.A.3	3 x 400	●	●	●			96010925
Unilift AP12.40.08.A.3	3 x 400	●	●	●		●	96023873
Unilift AP12.40.08.A.3	3 x 230	●	●	●			96010958
Unilift AP12.40.08.A.3	3 x 200	●	●	●			96010924
Unilift AP12.50.11.1	1 x 230			●		●	96001958
Unilift AP12.50.11.1	1 x 230			●			96001962
Unilift AP12.50.11.A.1	1 x 230		●		●	●	96001965
Unilift AP12.50.11.A.1	1 x 230		●		●		96001973
Unilift AP12.50.11.A.1	1 x 230		●	●		●	96010981
Unilift AP12.50.11.3	3 x 400			●			96001975
Unilift AP12.50.11.3	3 x 230			●			96010634
Unilift AP12.50.11.3	3 x 200			●			96010883
Unilift AP12.50.11.A.3	3 x 400	●	●	●			96010927
Unilift AP12.50.11.A.3	3 x 400	●	●	●		●	96023874
Unilift AP12.50.11.A.3	3 x 230	●	●	●			96010959
Unilift AP12.50.11.A.3	3 x 200	●	●	●			96010926

Unilift AP35

Pump type	Voltage [V]	Control box with 0.8 m supply cable	Float switch	10 m cable	3 m cable	With plug	Product no.
Unilift AP35.40.06.1.V	1 x 230			●		●	96001796
Unilift AP35.40.06.1.V	1 x 230			●			96001808
Unilift AP35.40.06.A.1.V	1 x 230		●		●	●	96001777
Unilift AP35.40.06.A.1.V	1 x 230		●		●		96001789
Unilift AP35.40.06.A.1.V	1 x 230		●	●		●	96010982
Unilift AP35.40.06.3.V	3 x 400			●			96000169
Unilift AP35.40.06.3.V	3 x 230			●			96010629
Unilift AP35.40.06.3.V	3 x 200						96010884
Unilift AP35.40.06.A.3.V	3 x 400	●	●	●			96010929
Unilift AP35.40.06.A.3.V	3 x 400	●	●	●		●	96023875
Unilift AP35.40.06.A.3.V	3 x 230	●	●	●			96010960
Unilift AP35.40.06.A.3.V	3 x 200	●	●	●			96010928
Unilift AP35.40.08.1.V	1 x 230			●		●	96001672
Unilift AP35.40.08.1.V	1 x 230			●			96001894
Unilift AP35.40.08.A.1.V	1 x 230		●		●	●	96001897
Unilift AP35.40.08.A.1.V	1 x 230		●		●		96001905
Unilift AP35.40.08.A.1.V	1 x 230		●	●		●	96010983
Unilift AP35.40.08.3.V	3 x 400			●			96001718
Unilift AP35.40.08.3.V	3 x 230			●			96010631
Unilift AP35.40.08.3.V	3 x 200			●			96010885
Unilift AP35.40.08.A.3.V	3 x 400	●	●	●			96010931
Unilift AP35.40.08.A.3.V	3 x 400	●	●	●		●	96023876
Unilift AP35.40.08.A.3.V	3 x 230	●	●	●			96010961
Unilift AP35.40.08.A.3.V	3 x 200	●	●	●			96010930

Unilift AP35B

Pump type	Voltage [V]	Control box with 0.8 m supply cable	Float switch	10 m cable	5 m cable	With plug	Product no.
Unilift AP35B.50.06.A1.V	1 x 230		●		●	●	96004562
Unilift AP35B.50.06.1.V	1 x 230			●		●	96004563
Unilift AP35B.50.06.3.V	3 x 400				●		96004565
Unilift AP35B.50.08.A1.V	1 x 230		●		●	●	96004574
Unilift AP35B.50.08.1.V	1 x 230			●		●	96004575
Unilift AP35B.50.08.3.V	3 x 400				●		96004577

Unilift AP50

Pump type	Voltage [V]	Control box with 0.8 m supply cable	Float switch	10 m cable	3 m cable	With plug	Product no.
Unilift AP50.50.08.1.V	1 x 230			●		●	96010595
Unilift AP50.50.08.1.V	1 x 230			●			96010599
Unilift AP50.50.08.A.1.V	1 x 230		●		●	●	96010584
Unilift AP50.50.08.A.1.V	1 x 230		●	●		●	96010984
Unilift AP50.50.08.A.1.V	1 x 230		●		●		96010592
Unilift AP50.50.08.3.V	3 x 400			●			96010563
Unilift AP50.50.08.3.V	3 x 230			●			96010632
Unilift AP50.50.08.3.V	3 x 200			●			96010886
Unilift AP50.50.08.A.3.V	3 x 400	●	●	●			96010933
Unilift AP50.50.08.A.3.V	3 x 400	●	●	●		●	96023877
Unilift AP50.50.08.A.3.V	3 x 230	●	●	●			96010962
Unilift AP50.50.08.A.3.V	3 x 200	●	●	●			96010932
Unilift AP50.50.11.1.V	1 x 230			●		●	96010577
Unilift AP50.50.11.1.V	1 x 230			●			96010581
Unilift AP50.50.11.A.1.V	1 x 230		●		●	●	96010566
Unilift AP50.50.11.A.1.V	1 x 230		●	●		●	96010985
Unilift AP50.50.11.A.1.V	1 x 230		●		●		96010574
Unilift AP50.50.11.3.V	3 x 400			●			96010562
Unilift AP50.50.11.3.V	3 x 230			●			96010633
Unilift AP50.50.11.3.V	3 x 200			●			96010887
Unilift AP50.50.11.A.3.V	3 x 400	●	●	●			96010935
Unilift AP50.50.11.A.3.V	3 x 400	●	●	●		●	96023878
Unilift AP50.50.11.A.3.V	3 x 230	●	●	●			96010963
Unilift AP50.50.11.A.3.V	3 x 200	●	●	●			96010934

Unilift AP50B

Pump type	Voltage [V]	Control box with 0.8 m supply cable	Float switch	10 m cable	5 m cable	With plug	Product no.
Unilift AP50B.50.08.A1.V	1 x 230		●		●	●	96004586
Unilift AP50B.50.08.1.V	1 x 230			●		●	96004587
Unilift AP50B.50.08.3.V	3 x 400				●		96004589
Unilift AP50B.50.11.A1.V	1 x 230		●		●	●	96004598
Unilift AP50B.50.11.1.V	1 x 230			●		●	96004599
Unilift AP50B.50.11.3.V	3 x 400				●		96004601
Unilift AP50B.50.15.3.V	3 x 400				●		96004609

96604141 0209	GB
Repl. 96604141 0109	

Subject to alterations.